

casegoods



Collectibles

India Design ID 2024, Delhi

casegoods



Collectibles

As with all of our work, our aim with these collectible pieces is to produce work of lasting value that is simple, beautiful, and functional. We aspire to make pieces that can be used and enjoyed for generations to come.

Some of the pieces shown here are drawn from our existing catalogue of furniture, lights, and objects explored in different materials, proportions, and finishes. Others, seen here for the first time, are newly realised works, created specifically for this space.

About

Casegoods was born out of a passion for materials, a commitment to the act of making, and an awareness of our impact as designers on the shared environment. We believe that the greatest form of sustainability is to produce work of lasting value. In that spirit we endeavour to design products that are simple, beautiful, functional and can be cherished for generations. Our products are rooted in the Indian tradition of craft while remaining considerate to contemporary living.

Making of ID 2024

Every piece demonstrates our curiosity and fascination with the materials we work with and the continuous exploration, iteration, and distillation undertaken by our team. Our palette incorporates aluminium, brass, teak, rosewood, refractory clay, marble, and sandstone. Inspired by how we might translate nature, the Cast Bamboo Handles in brass represent our recent engagement with natural forms and their tactile qualities. The slenderness of the Hold Shelf represents how we might push the limits of materiality and frame seamless connections to create an object focused on visual integrity. The understated sophistication of these pieces is built around the notion of invisible engineering while engaging with essential connections and details. Responding to the subtle variations of grain, figure, and texture of materials, we strive to push ourselves to achieve works of the highest quality.

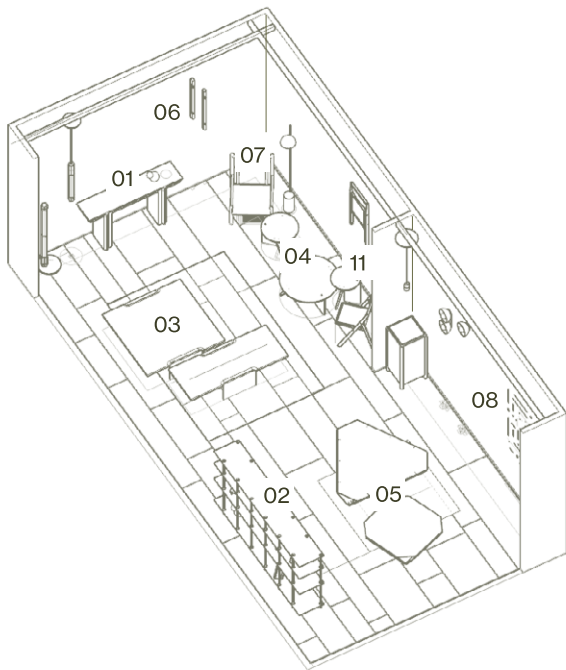

Content

01	Profiled Stone Console	9
02	Hold Shelf	13
03	Fillet Joint Tables	17
04	Slant Side Tables	21
05	Truncated Pyramid Table	25
06	One Tube Light	31
07	Woven Back Chair	35
08	Cast Bamboo Handles	37
09	Alcove	41
10	Splayed Plank Table and Bench	45
11	Folding Flat Chair	49
12	Topologic Bowls	53
	Casegoods x Atelier Pesmois	56
	Casegoods x FRAMA	57
	Process	58
	Product Offering	59



Profiled Stone Console

Materials
Grey Sandstone

Drawing from monoliths and craft histories, the console is designed in three parts. A profiled edge seamlessly transitions across the horizontal and vertical members reducing the visual weight of the slabs. Machined from blocks of grey sandstone, the stacked stone slabs are meticulously shaped and joined, polished and sealed.

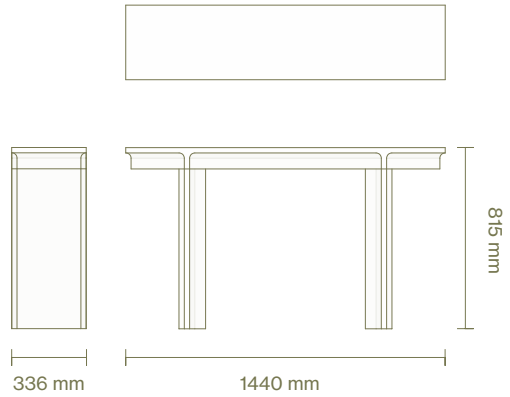



Hold Shelf

Materials

Rosewood

Rosewood Veneer

Plywood

Brass Hardware, Blackened

Designed to push material limits, the Hold Shelf is structured using a combination of alternating slender columns that support lean shelves. The capitals not only reinforce each level but also blend into the structure, thus framing seamless connections and enhancing its overall visual integrity. Normally produced in aluminium, this version in exquisite rosewood is made to order.

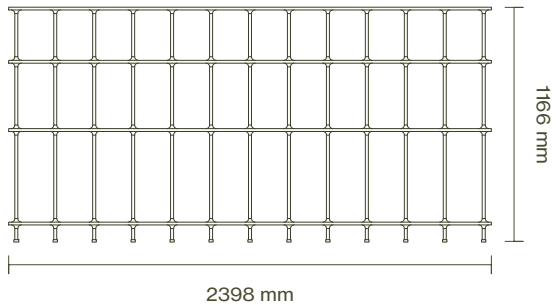



Fillet Joint Tables

Material

Teak Frame

Teak Top

Design

Atelier Pesmois x Casegoods

This series of tables celebrates the geometries of connections, and is designed around the notion of a rounded corner. In accentuating the points of formal contact at the joints, the magnified fillets make invisible the transitions and transfers of forces. Made from various combinations of wood and stone, this series has been designed in collaboration with France based *Atelier Pesmois*.

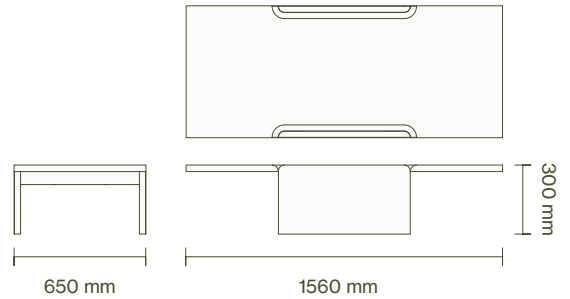
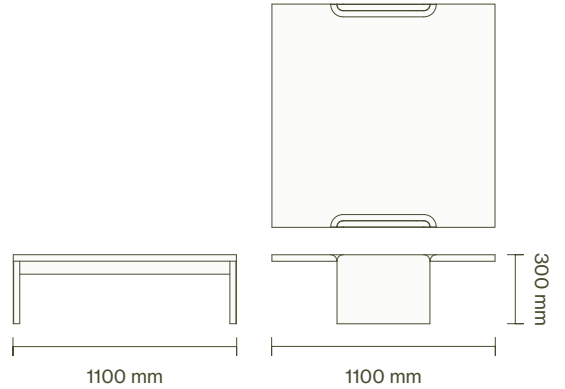
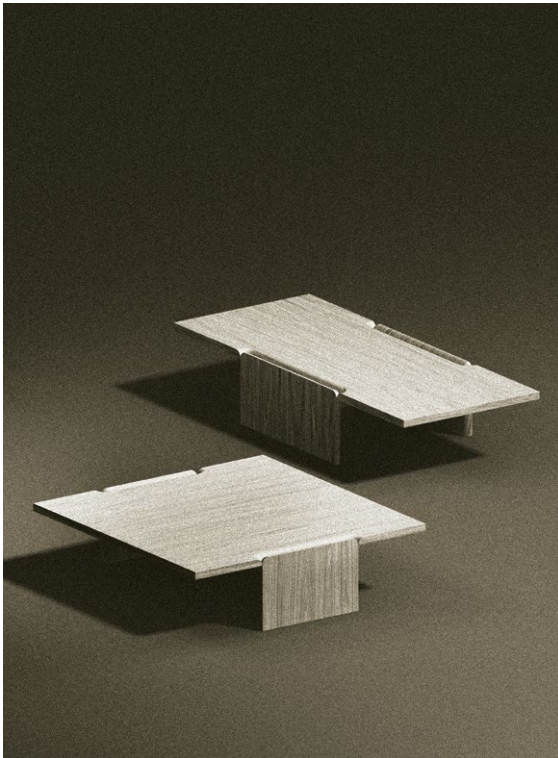



Slant Side Tables

Materials

Teak

Rosewood

Stainless Steel Hardware

A family of round wooden side tables based on arrangements of intersecting planes coming together with a single custom screw, demonstrating a sophisticated assembly. A convergence of circular, rectilinear and inclined geometries, this table is designed to be flatpack and is available in multiple sizes.

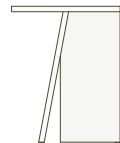
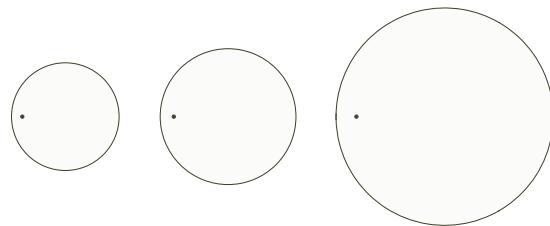

400 mm
H 500 mm



500 mm
H 400 mm

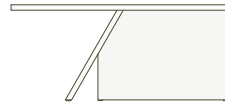

800 mm
H 350 mm

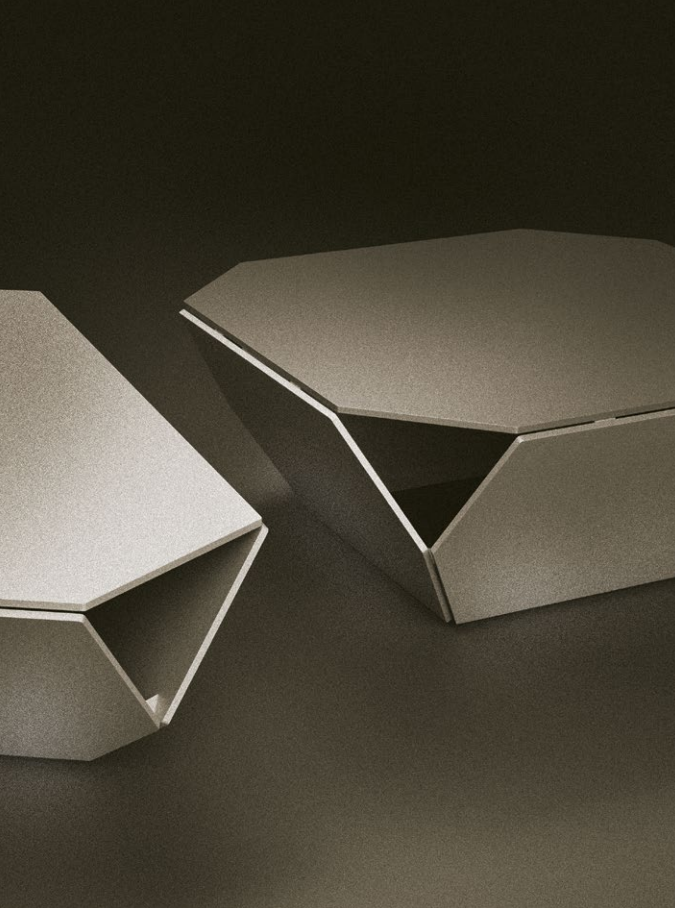

Truncated Pyramid Tables

Materials

Aluminium, Anodised Neutral & Black

This series of centre tables is produced using solid aluminium plates each imperceptibly connected, yet separated and seemingly floating. Designed using parametric modelling software, engineered using critical tolerances for streamlined assembly, the tables are entirely produced by CNC processes. Available in anodised finishes with opportunities for form customisation.

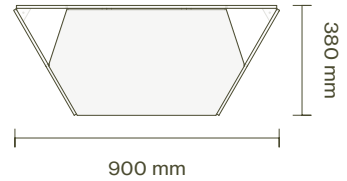
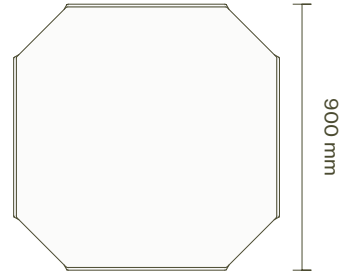
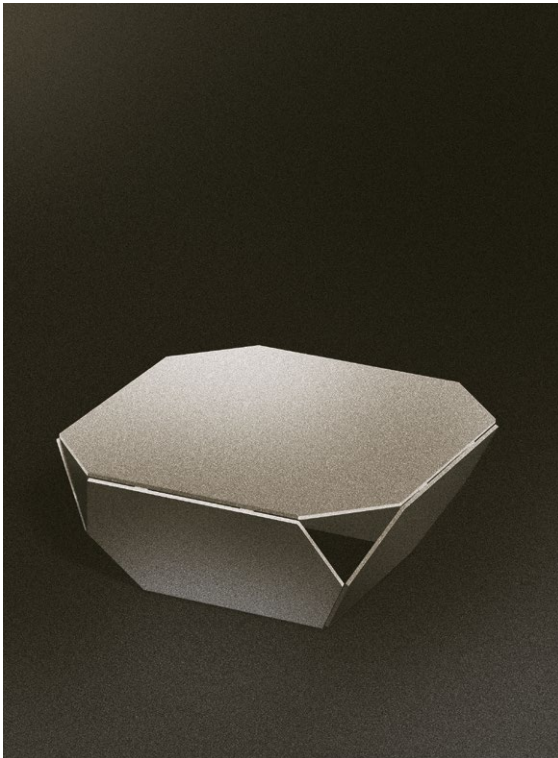

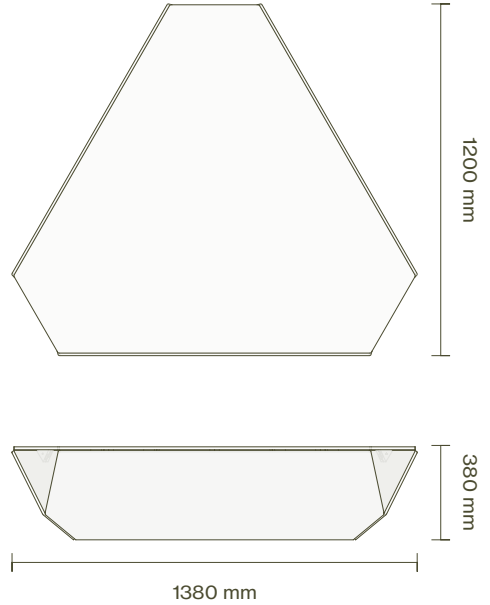



One Tube Light

Materials

Brass, Blackened

The One Tube Light uses an industrially produced fluorescent glass tube as the light source, housed precisely within a symmetrical brass enclosure. This single version of our Seven Tube Light is a new product launch in our catalog products.

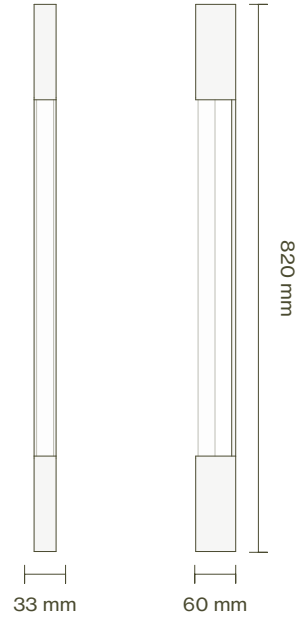
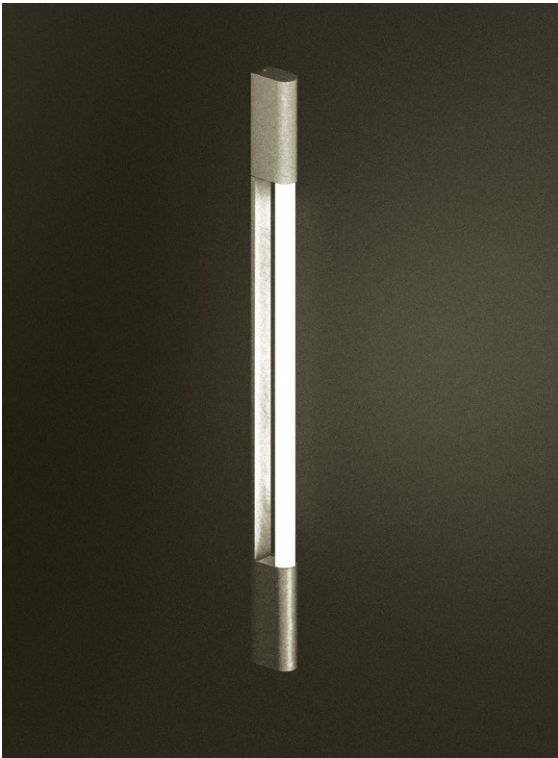



Woven Back Chair

Material

Teak

Cotton rope

Foam Seat

Seat Fabric by *Leel*

This special edition of the Woven Back Chair is customised using seat fabric woven by Kutch weavers sourced from brand *Leel*. An extension of our existing family that includes a bench, this Burma teak chair continues our furniture explorations incorporating weaves and colours.

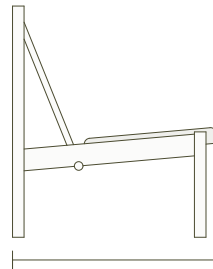
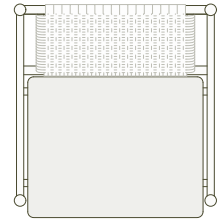
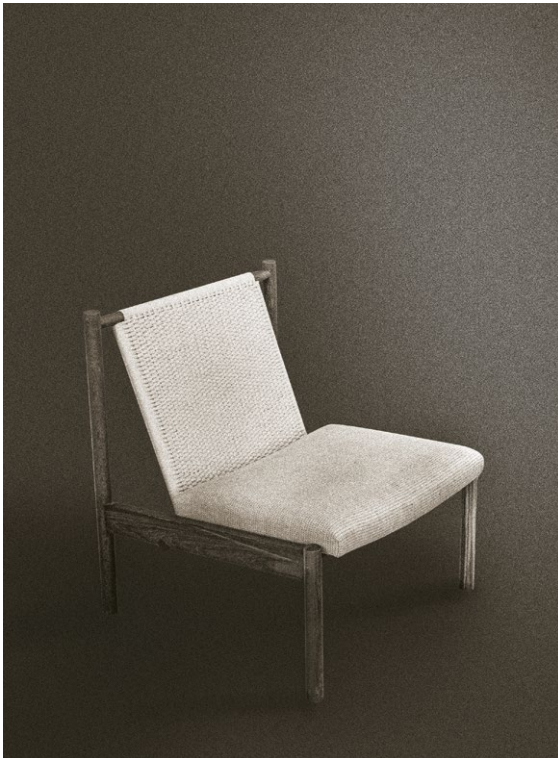

740 mm

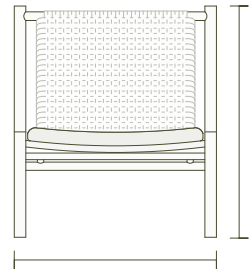

800 mm

700 mm

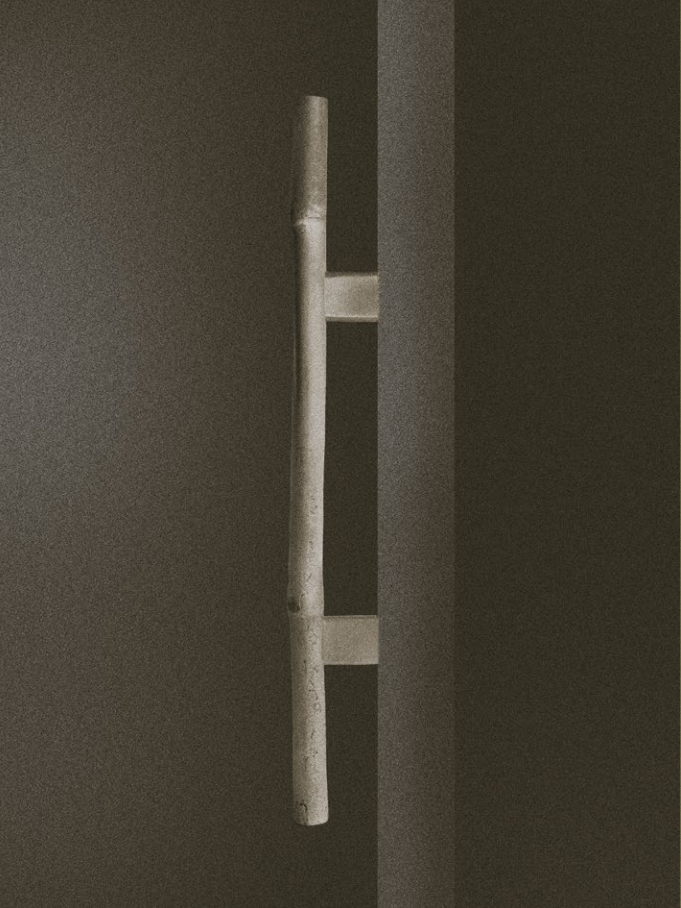

Cast Bamboo Handles

Materials

Brass, Casted

Brass, Machined

Locally sourced bamboo is cast in solid brass to carefully achieve the qualities of its natural form. Effectively resulting in an artefact translated from nature, the Bamboo Handle series offers variety in size, proportion, character and typology for a range of applications.

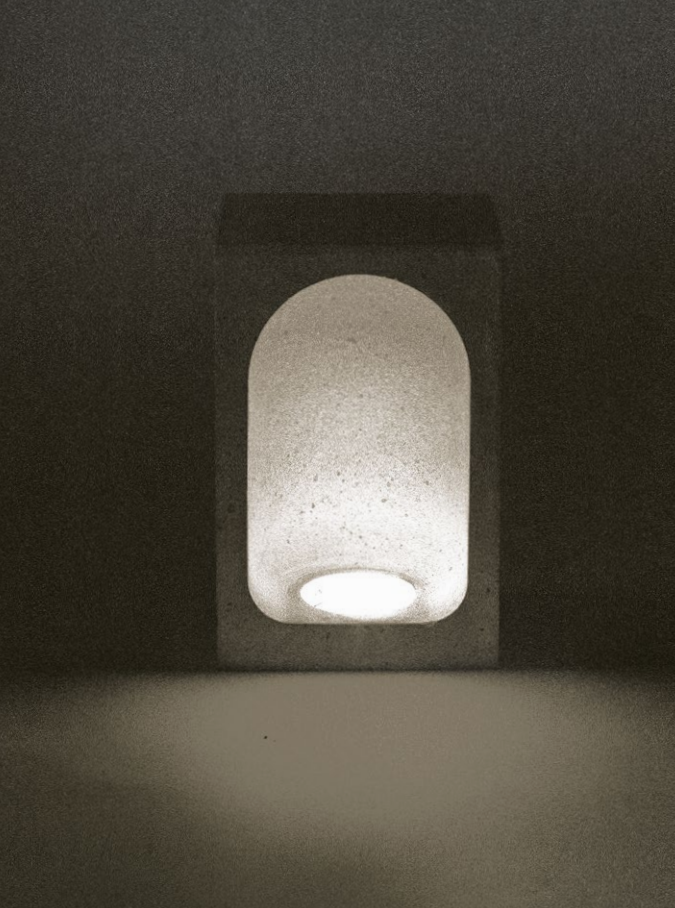

Alcove

Tea Light Candle-Holder

Materials

Refractory Brick

Stainless Steel vessel

This tea light candle-holder is inspired from niches in traditional Indian architecture, where recessed pockets in the walls prevented lamps from blowing out in the wind. It is made with locally available clay using a refractory brick composition resulting in distinct surface textures. Defined by the extents of the light reduced to its simplest spatial geometry, the Alcove vanishes when lit in the dark, with only a warm glow visible within its soft form .

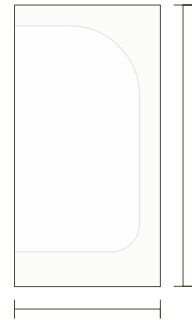
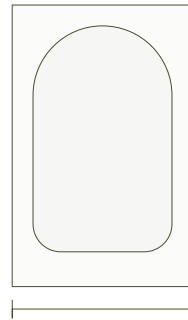

84 mm

Splayed Plank Table & Bench

Materials

Teak

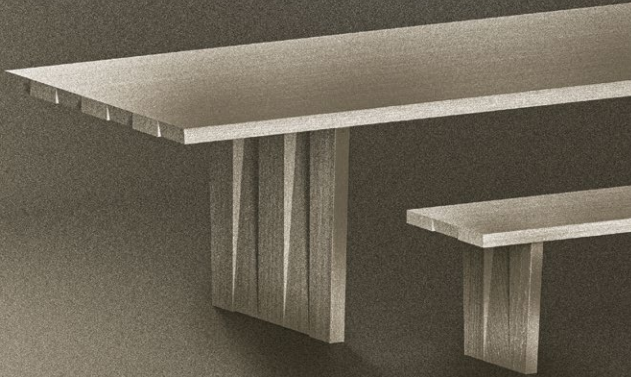

The solid wood Alternating furniture series includes a table and bench, and is based on accentuating every member that constitutes the otherwise unified wooden panels. Subtle inclinations in the legs are designed to provide structural strength.

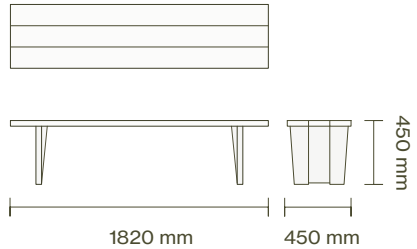
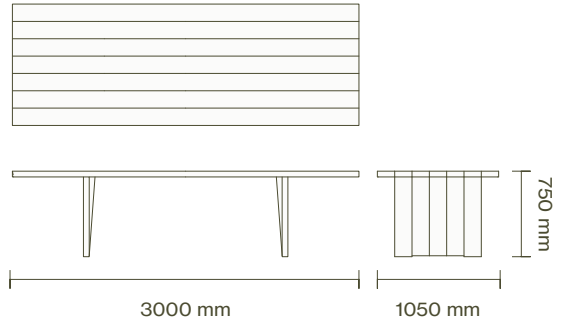



Folding Flat Chair

Materials

Rosewood, Press Leather Seat

Teak, Teak Veneer Seat

Workmanship and understated proportions define this meticulously crafted multipurpose chair. Folding to a mere 4cms (1 ½ inch), this lightweight chair allows for portability and ease of storage, from hanging it on a wall to sliding it into narrow spaces. Its standard version is constructed of solid wood frames, a carved backrest, stainless steel and brass hardware, and a seat that is available in various finishes—either natural wood, pressed leather or slung leather. This chair design has also been licensed to the Denmark based international brand FRAMA. The special edition rosewood chair on display reinforces our focus on materiality and refinement.

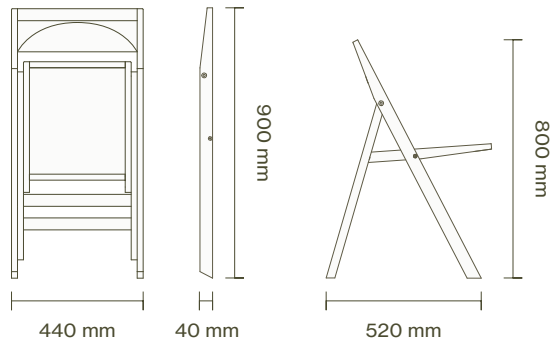



Topologic Bowls

Materials

Pink Granite

Sienna Gold Marble

A collection of shallow vessels, these geometric solids share the same topologic properties starting with a cylindrical volume. The hollow of the bowl is formed by removing a spherical portion while the outer surface is faceted from its outer circumference to meet a perfectly inscribed triangle at the bottom. Form and function are then derived from variation in material and the three basic parameters: diameter, height, and base shape. Normally produced in Teak and Mahogany, this special edition is made from a selection of stones.

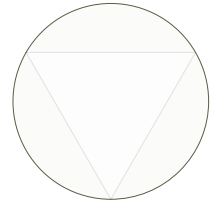
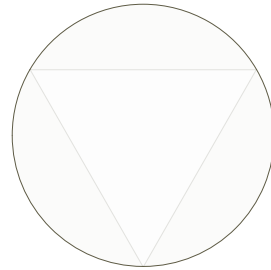

Ø 400 mm

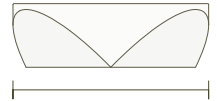

Ø 300 mm

Casegoods x Atelier Pesmois

Casegoods is uniquely positioned to collaborate with world-class designers, artists, and architects. An early and long standing member of the Casegoods team, Paul Michelin has returned to his native France to establish Atelier Pesmois, a design and production studio in southern France. Reuniting with our team specifically for this project, the Fillet Joint Table is a reflection of the collaborative nature of the studio and our deep fascination with materials and the process of design through making.

Created for this exhibition and seen here for the first time, the Fillet Joint Table is designed around the notion of a rounded corner between two surfaces. Taking this small detail to the edge of excess, the condition is scaled to create a unique and playful transition between materials and planar elements.

Casegoods x FRAMA

Designed by Casegoods, the Folding Flat Chair will soon be available worldwide in a range of woods/finishes through our collaboration with FRAMA, a Danish design brand built around the notion of timeless design & honest materials. The partnership developed organically through our collaborative approach to design and our shared values. With an eye towards sustainability, the opportunity to collaborate with FRAMA and have our designs produced and sold in Europe was a natural extension of our ethos.

Released in Paris on February 15, 2024, these new editions of the Folding Flat Chair will soon be available worldwide.

Process

Our products are made from a variety of conscientiously sourced materials by engaging with a diverse range of artisanal groups, each focusing on a different material, technique, or discipline. Many of these collaborators come from a lineage of traditional craft that stretches across generations and regions. By combining tacit knowledge, state of the art technology and unique skills with contemporary techniques, we look for the most efficient and sustainable systems of production specific to each product.

Each product we make goes through a thorough development process that considers performance, durability, aesthetics, and material life-cycle. By integrating workshop culture within our own practice, we are able to quickly and efficiently turn sketches into prototypes, increasing our ability to study, review, and improve each product and detail.

Product Offering

Casegoods' portfolio offers a range of our standard products spanning furniture, lights, objects, textiles, and hardware, that can be purchased directly through us or our global retailers. A key contributor to our growing range has been our most valued and discerning patrons who approach our team to create bespoke pieces for their spaces. Our dedicated team is ignited by the challenge of creating pieces that are exclusively tailored to our patrons' vision, allowing us to be explorative and combine our love for materials and design with the needs, preferences or constraints presented. Developing a personalised environment requires mutual trust, an open dialogue and mindset to push limits, and careful attention to design and reliable delivery.

