

casegoods





Introduction

Casegoods has established itself as an international brand with a unique position in the world of product design and manufacturing. Our practice was born out of a passion for materials and a commitment to the act of making. Rooted in Mumbai, a design and cultural center of India, Casegoods pays homage to the Indian tradition of craft while remaining considerate to contemporary living.

Our collection of furniture, lights, objects, textiles, and hardware is made from a variety of conscientiously sourced materials by engaging with a diverse range of artisanal groups, each focusing on a different material, technique, or discipline. Many of these collaborators come from a lineage of traditional craft that stretches across generations and regions. By combining tacit knowledge and unique skills with contemporary techniques, we look for the most efficient and sustainable systems of production specific to each product.

We believe that the greatest form of sustainability is to produce work of lasting value and endeavour to design products that are simple, beautiful, and functional.

Staying true to our core values, throughout our process we reflect on how our practice can improve the lives of all involved and make a positive impact. We recognize that our greatest impact can be achieved in the design stage and that sustainability, in all forms, must be at the core of what we produce. We contribute to the positive evolution of working practices in our field - from realigning perceptions of value and beauty with our customers to improving supply chain and worker standards with our partners - with the aim to be better stewards of the environment.

We make pieces that we want to use ourselves, are proud to share with others, and will not compromise the lives of future generations.

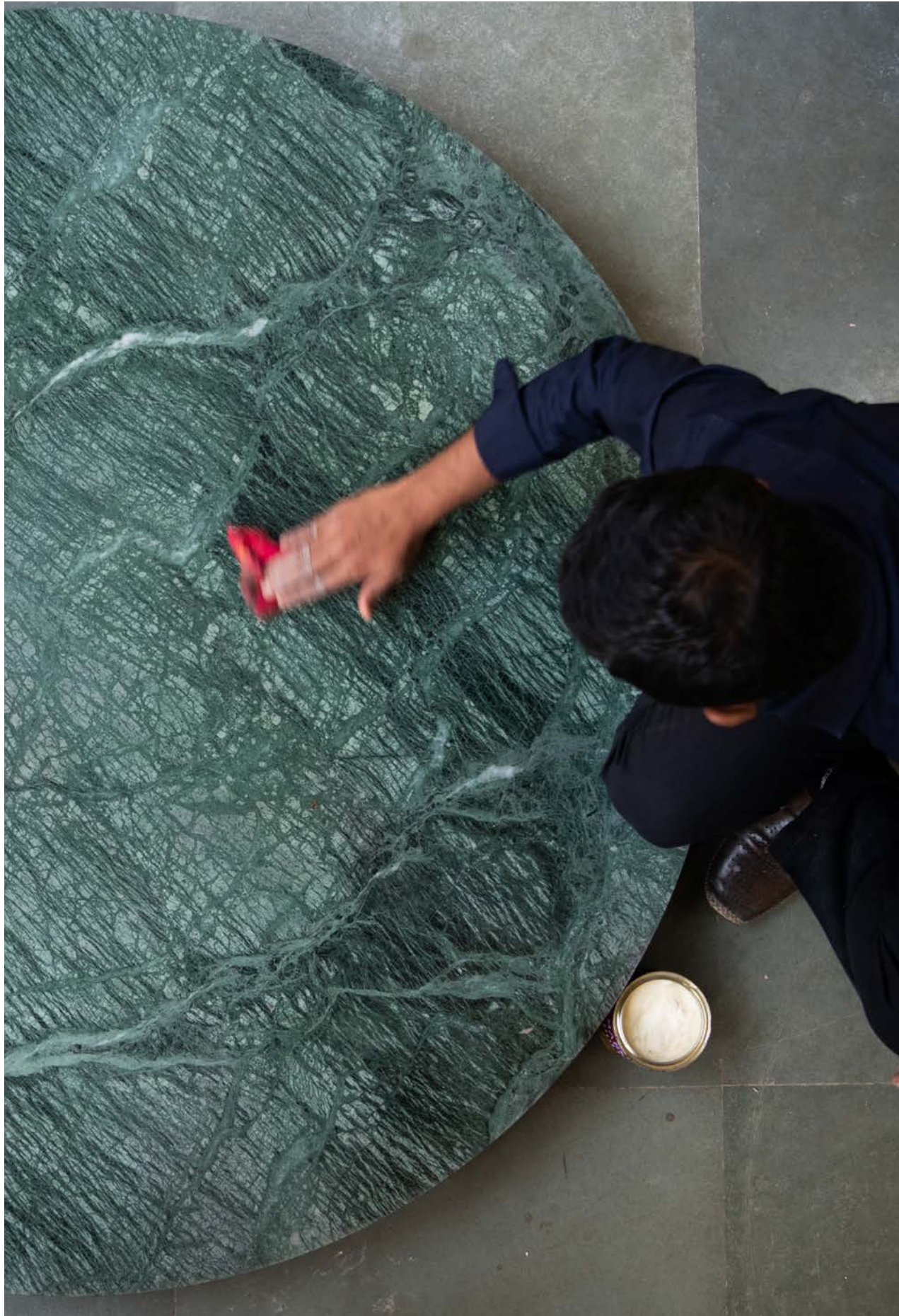

Process

Our work is a reflection of our unique access to a wide array of materials, methods, and production techniques. We are able to work with state of the art technology while still maintaining access to knowledge, skills, and processes that existed thousands of years ago and have been passed down through generations of craft and oral tradition.

Each product we make goes through a thorough development process that considers performance, durability, aesthetics, and material life-cycle. By engaging deeply with the craftspeople involved in our production and integrating workshop culture within our own practice, we are able to quickly and efficiently turn sketches into samples and prototypes, increasing our ability to study, review, and improve each product and detail. Through iteration and distillation, we strive to create products that can be used and cherished for generations.

As thoughtful citizens, we are keenly aware of our imprint on culture, consumption, and the environment. To reduce unwanted impact, we use carefully selected resources - natural, reclaimed, recycled, and recyclable materials - that are locally available in India. Our palette includes sustainably sourced and reclaimed timber, natural stone, recycled glass, recyclable metals, and natural fibers.

We regularly reexamine our product line and develop new pieces with a focus on lifecycle and longevity. Each product we make is designed in a way that can be dismantled into components ensuring easy repair and prolonged use.

We take pride in our focus on detail and quality. Whether it is the honed finish on a marble table top, the hand rubbed patina of a brass dome, or the polished surface of a wooden bowl, each piece is thoroughly inspected before leaving our workshop. We strive to accentuate the character of our products by highlighting the subtle variations of grain, figure, and texture found in the raw materials. Our finishes are applied in a way that enables them to patinate through use and time deepening their unique character and natural beauty.

How our pieces are developed matters to us and we believe it should matter to you as well.

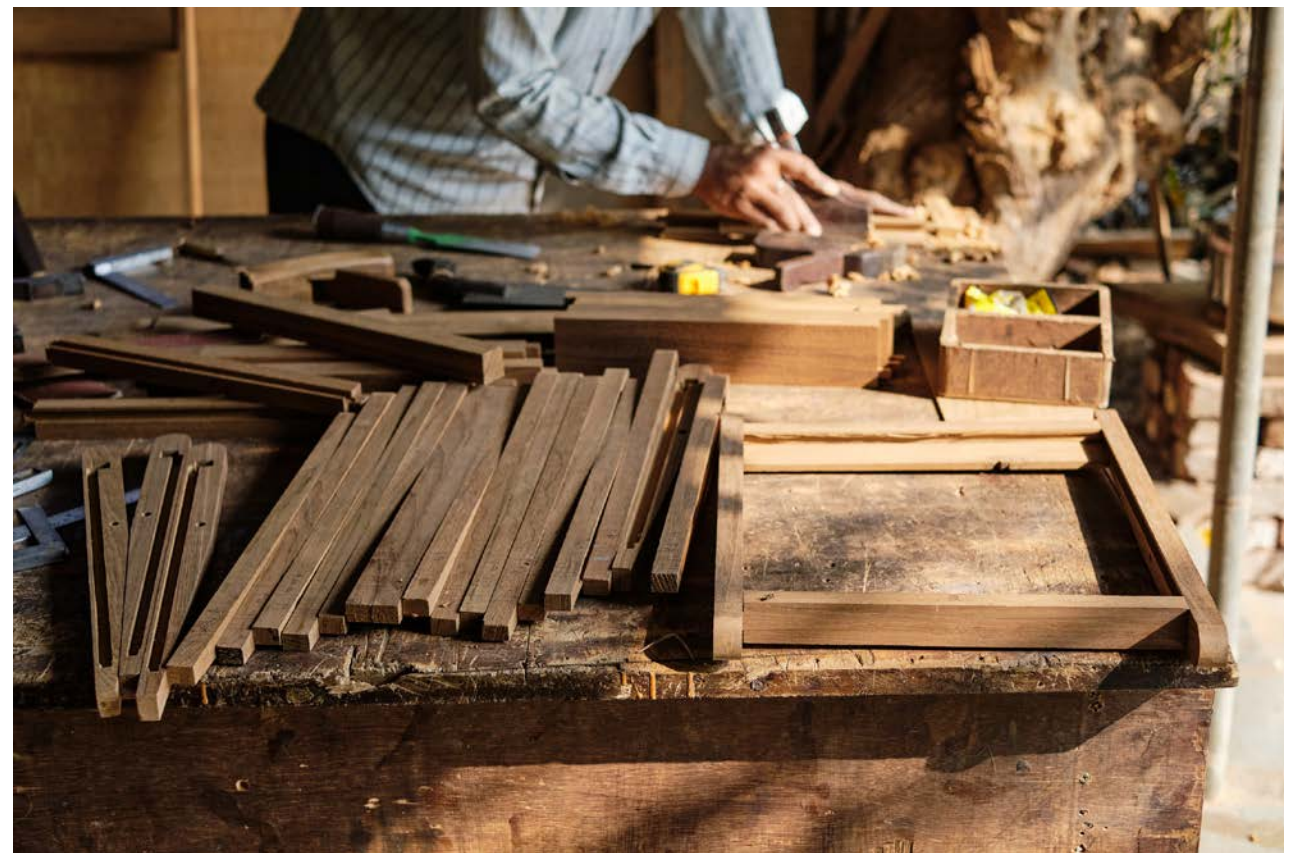



People

Established in 2021 by Samuel and Erica Barclay, and Saleem Bhatri, Casegoods operates today under the leadership of Creative Director Kenneth Rodrigues and CEO Raseel Sehmi.

As both a brand and creative practice, Casegoods is engaged in design and production with a diverse and exceptional team of makers, contributors, and collaborators from across the globe.

Our relationships are the foundation of our success. We collaborate with craftspeople, artisans, vendors, and small scale manufacturers from all over India to identify appropriate methods, develop premium products for our bespoke and catalogue customers, and export to our valued stockists and retail partners worldwide.

Collectively, we bring a deep understanding of materials and techniques, an openness to dialogue and to engage in an iterative design practice to achieve the best outcome, a belief in artistic freedom and the creative process, and a commitment to quality work across any scale.

Working with the likes of Frama, Atelier Pesmois, Van Rossum and others, we believe in showcasing and collaborating with talented designers and partners to bring new products to market for our community.

Combined with our in-house design, production, and multi-disciplinary teams, Casegoods is uniquely positioned to both envision and realise work of exceptional quality and lasting value. Our hope is that you get to witness first-hand the work we are privileged to showcase to the world.



| | | | |
|---------------------------|---|-----------------------------|--------------------|
| <i>Collection</i> | Furniture | Folding Flat Chair | 19 |
| | | Hold Shelf | 27 |
| | | Trestle Table | 35 |
| | | Pinned Trestle Table | 45 |
| | | Right Triangle Table | 51 |
| | | Stone Wood Table | 59 |
| | | Three Cylinder Table | 69 |
| | | Three Leg Table | 77 |
| | | Profiled Stone Console | 85 |
| | | Fillet Joint Table | 89 |
| | | Slant Side Table | 97 |
| | | Truncated Pyramid Table | 101 |
| | | Woven Back Chair | 109 |
| | | Splayed Plank Table & Bench | 115 |
| | | Lights | Front Facing Light |
| Rolling Round Light | 129 | | |
| Seven Tube Light | 135 | | |
| One Tube Light | 149 | | |
| Art Light | 153 | | |
| Standing Straight Lamp | 169 | | |
| Objects | Buenos Diyas | | 181 |
| | Building Blocks | 189 | |
| | Chulha | 195 | |
| | Dipa | 203 | |
| | Topologic Bowls | 209 | |
| Textiles | Fold Dhurries | 217 | |
| Architectural Hardware | Topologic Collection of Pulls and Knobs | 225 | |
| | Cylinder Collection of Handles | 229 | |
| | Offset Collection of Handles | 233 | |
| | Cast and Faced Collection of Handles | 237 | |
| | Cast Bamboo Collection of Handles | 241 | |

| | | | |
|----------------|-----------|-----------------------------|-----|
| <i>Bespoke</i> | Furniture | Gouge Edge Table & Bench | 247 |
| | | Flared Leg Table | 251 |
| | | Cast Brass Bench | 255 |
| | | Cast Brass Table | 257 |
| | | Profiled Stone Console | 259 |
| | | Upholstered Bed | 261 |
| | | Wood Music Box | 263 |
| | | Wood Console | 265 |
| | | Head Board | 267 |
| | | Two Level Desk | 269 |
| | Lights | Dome Uplight | 271 |
| | | Bespoke Front Facing Lights | 273 |

| | | |
|------------------|---------------------------|-----|
| <i>Materials</i> | Wood | 277 |
| | Metal | 279 |
| | Stone & Terrazzo | 281 |
| | Fabrics, Fibres & Leather | 283 |

| | | |
|--------------|--------------------|-----|
| <i>Other</i> | Stockists | 285 |
| | Credits | 287 |
| | Team | 289 |
| | Studio Information | 291 |

Folding Flat Chair



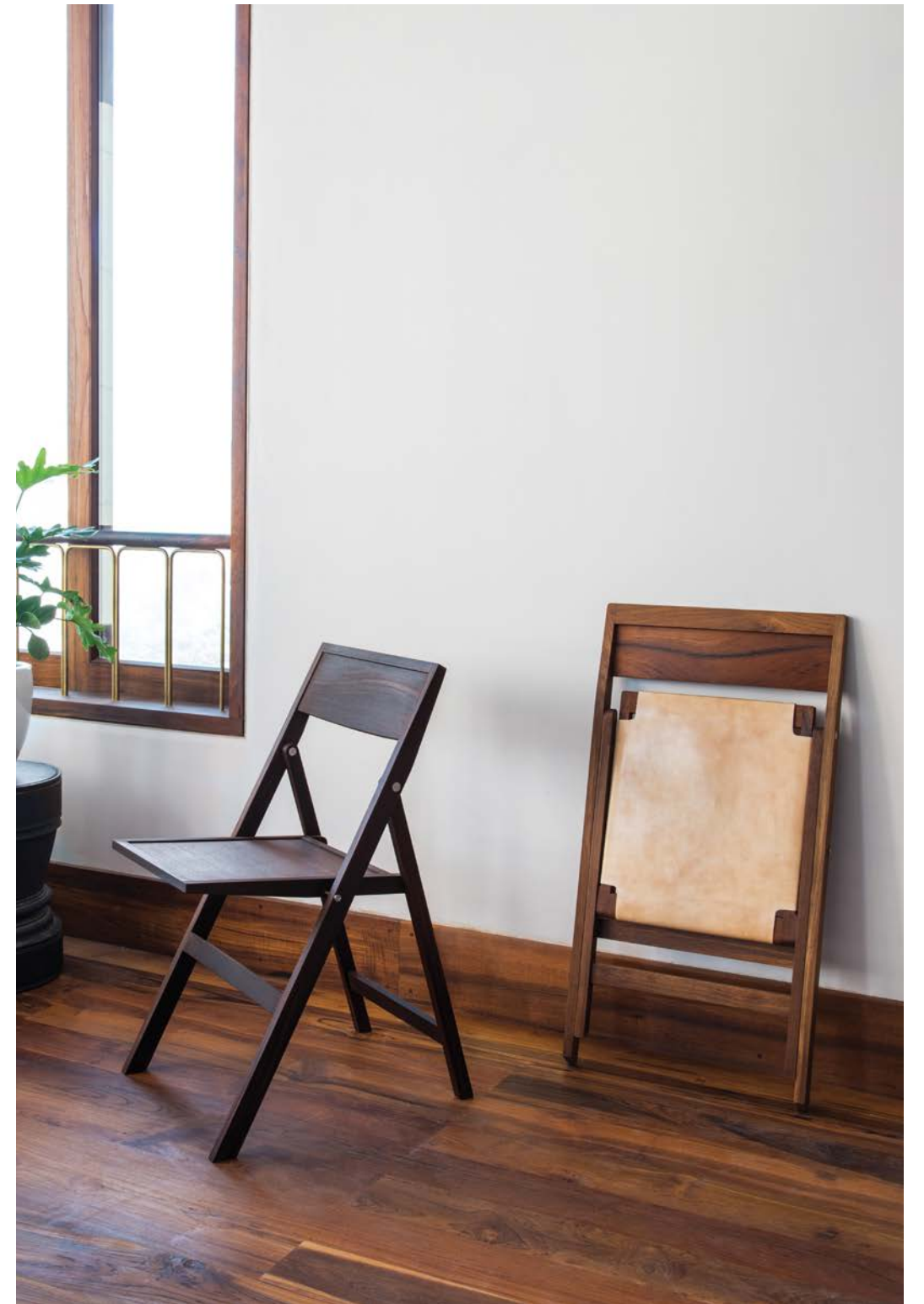

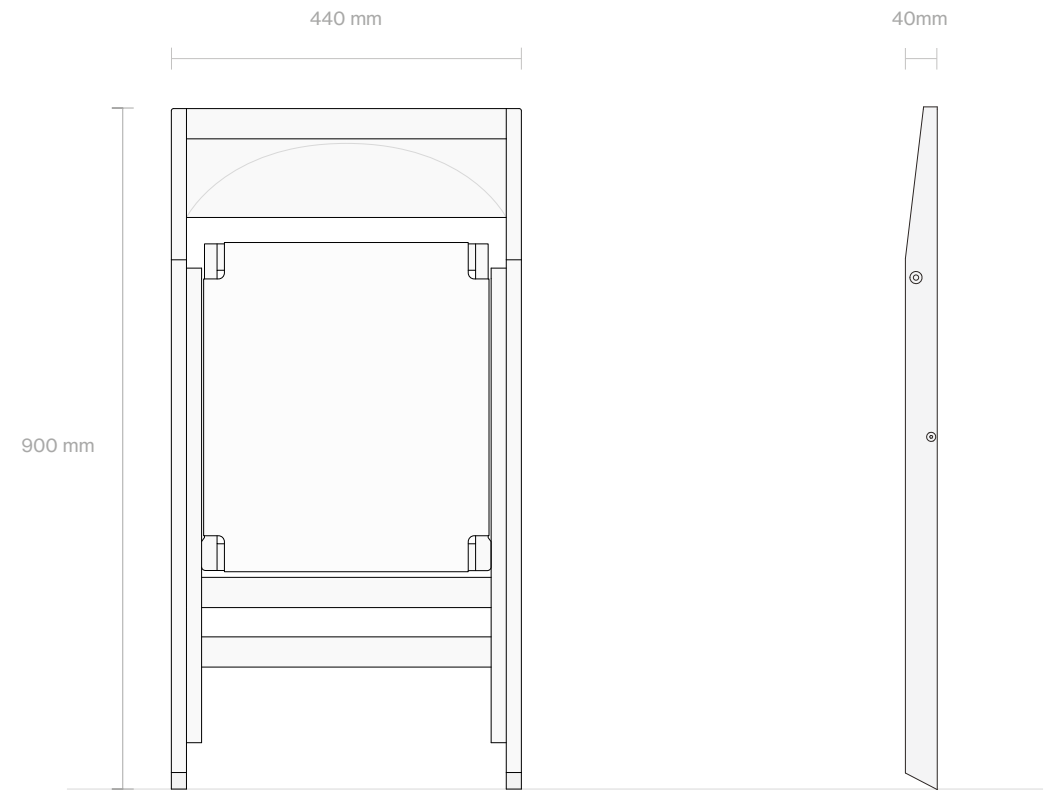
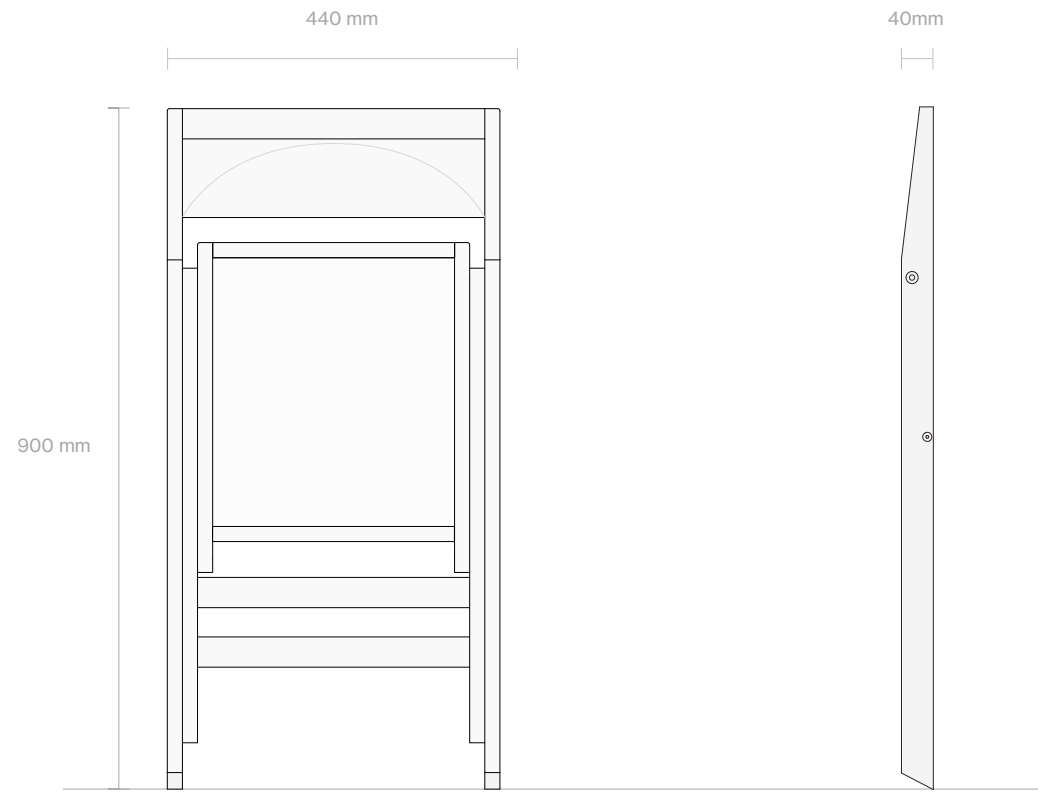

Standard & Pressed Leather Seat

Slung Leather seat

Specifications

Material & Finish

Frame

Finish

Teak _____ Oiled
 Teak _____ Black Stained

Solid Seat

Teak _____ Oiled
 Teak _____ Black Stained

Pressed Leather Seat ¹

Red
 Green
 Natural Buffalo

Slung Leather Seat ²

Natural Buffalo

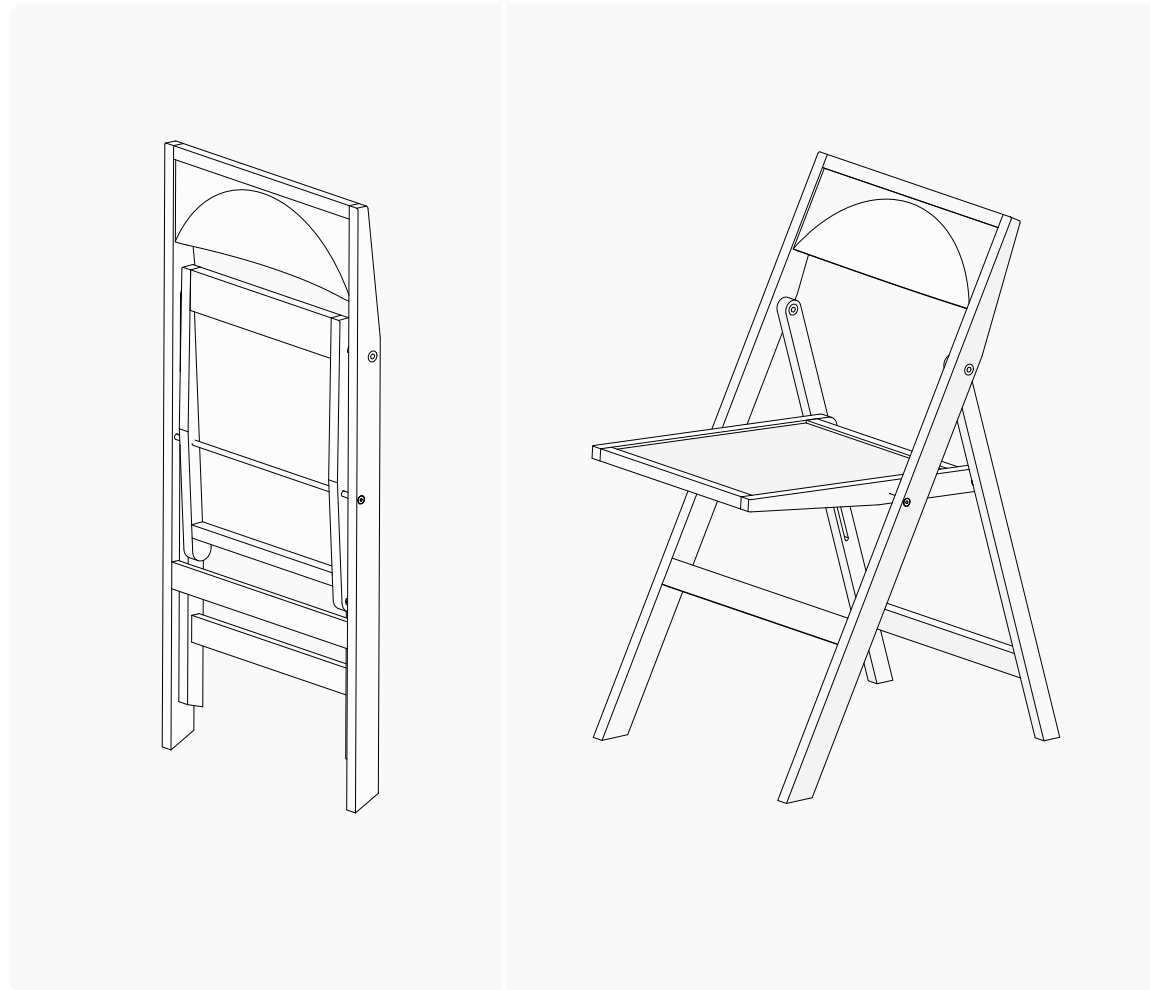

1 Other pressed leather colors available upon request with a minimum order quantity of 8.
 2 Slung leather available only in natural leather color.







Specifications

Material & Finish

Body

Finish

Aluminium ¹ ————— Neutral Anodised

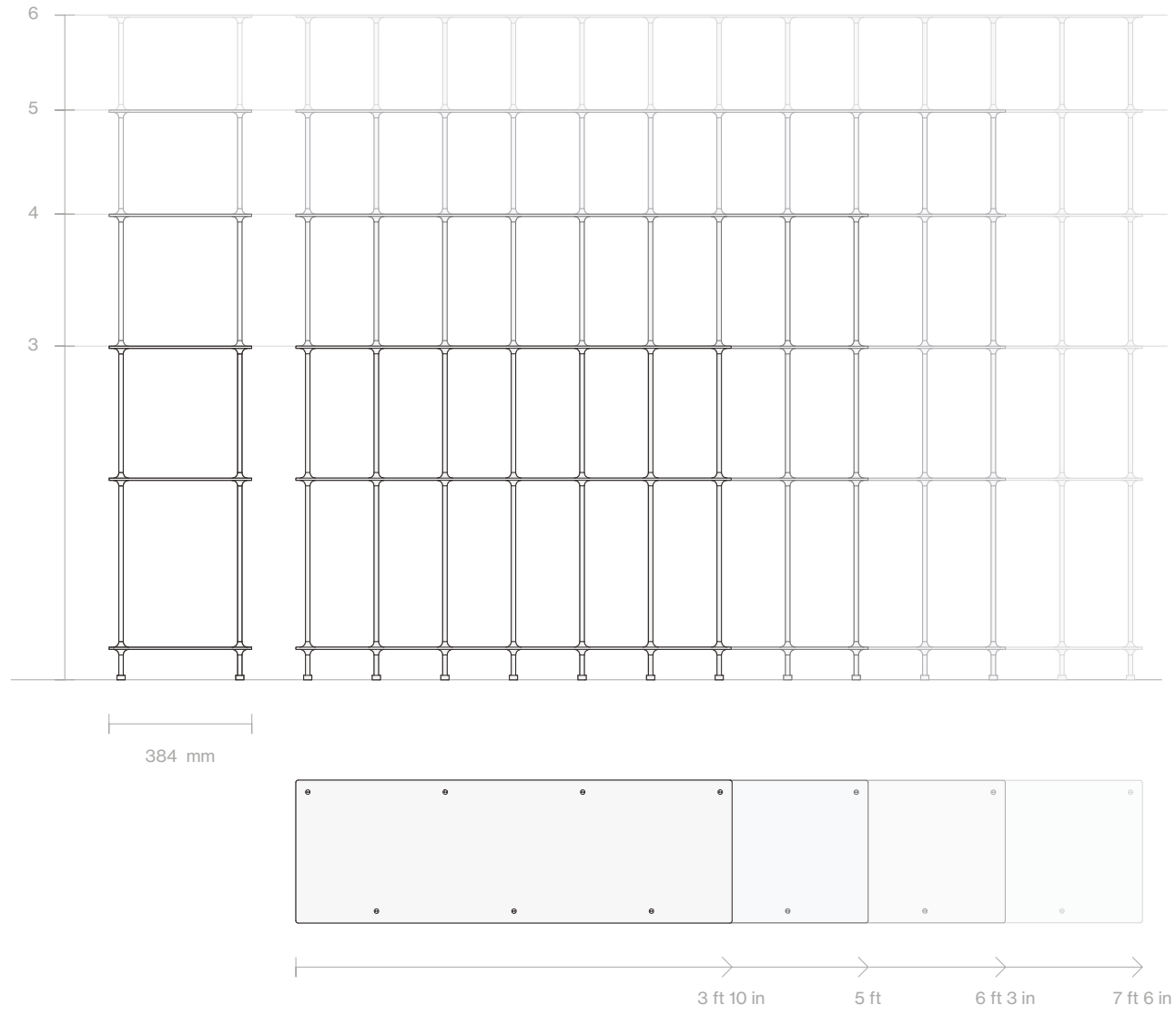

1

Other anodized aluminium colours available upon request.





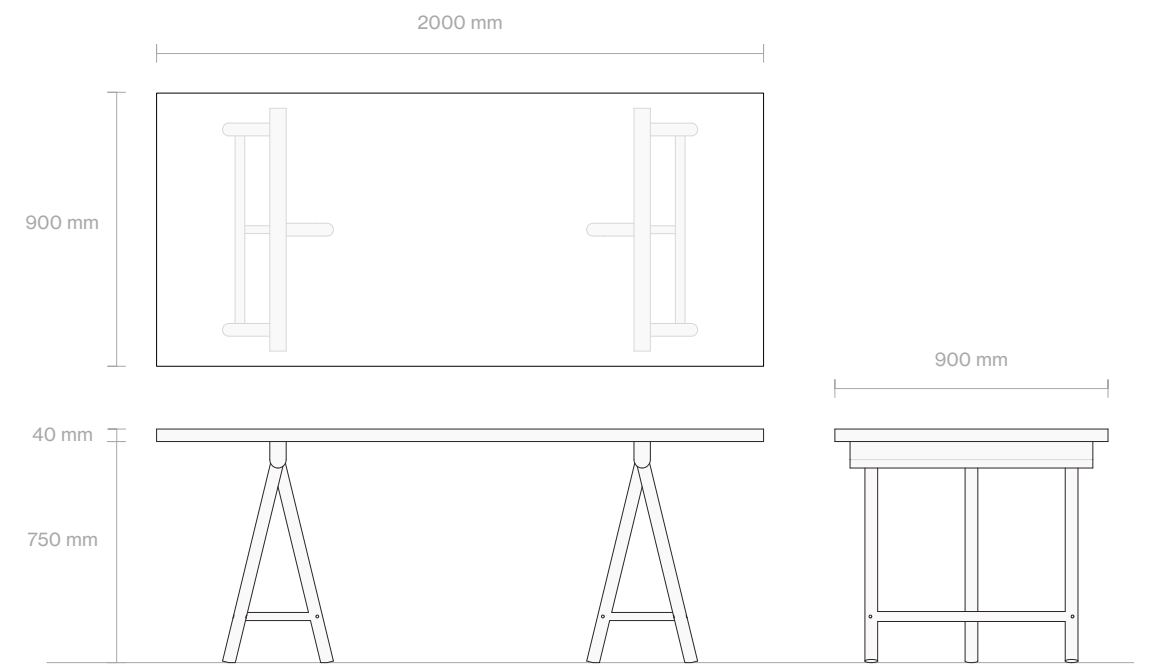
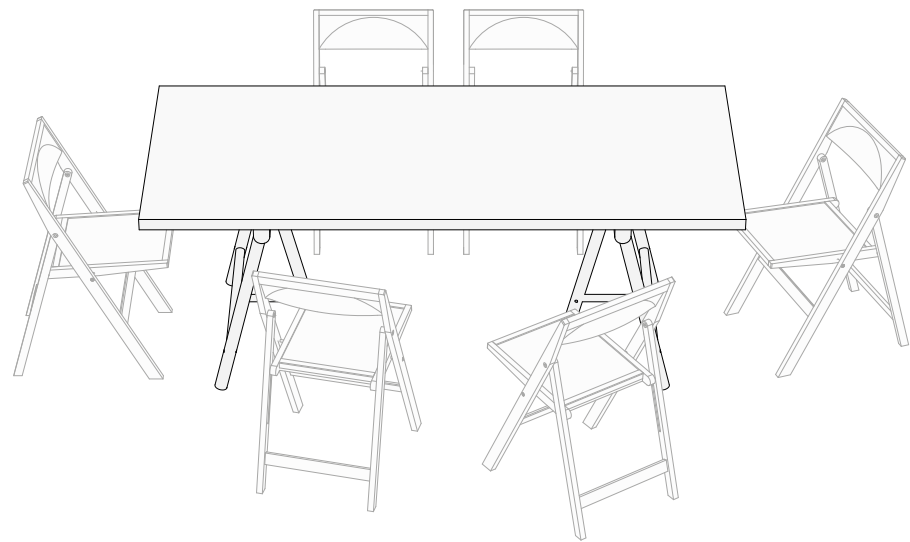

4-6 Seater

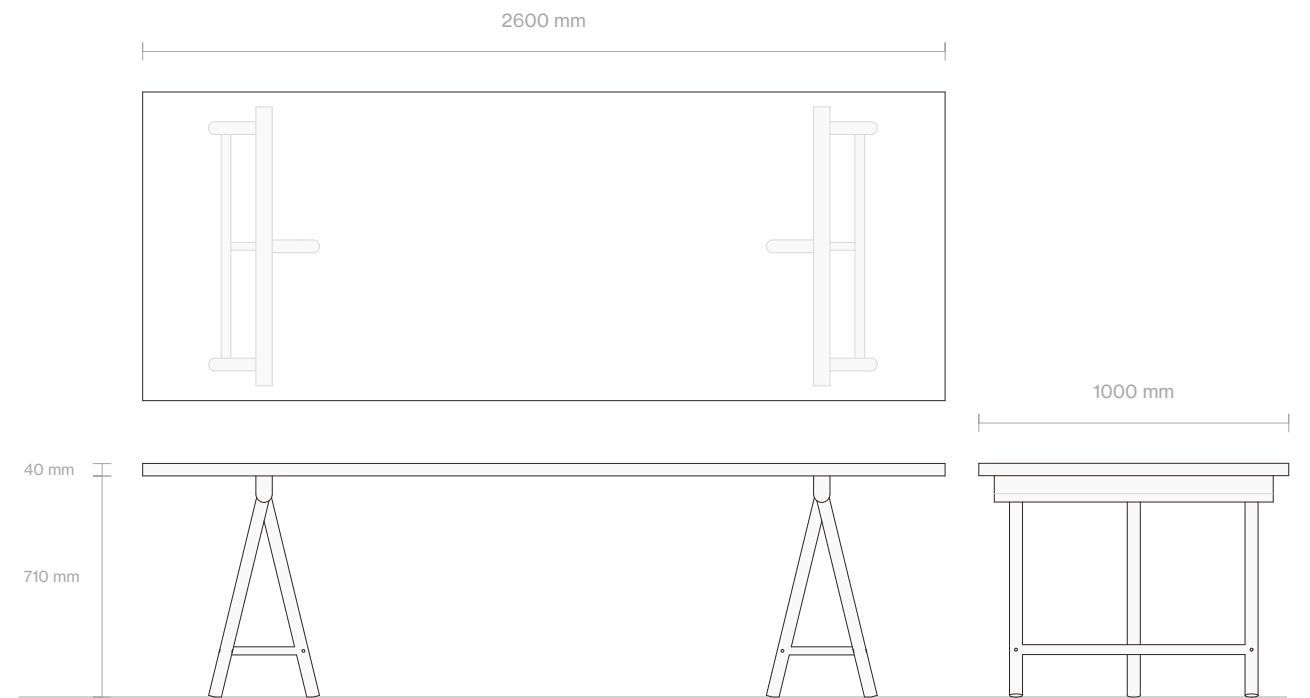
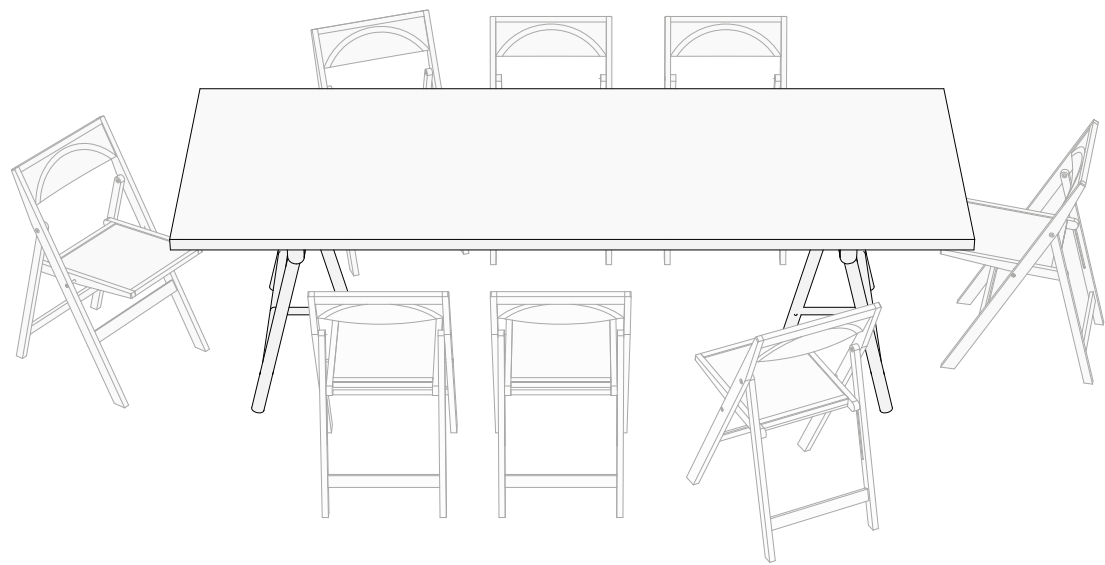

6-8 Seater

Specifications

**Material
& Finish**

Top

Finish

| | | |
|--------------|-------|----------------|
| Teak | _____ | Oiled / Sealed |
| Rosewood | _____ | Oiled / Sealed |
| Terrazzo | _____ | Polished |
| White Marble | _____ | Polished |

Legs

| | | |
|----------|-------|----------------|
| Teak | _____ | Oiled / Sealed |
| Rosewood | _____ | Oiled / Sealed |

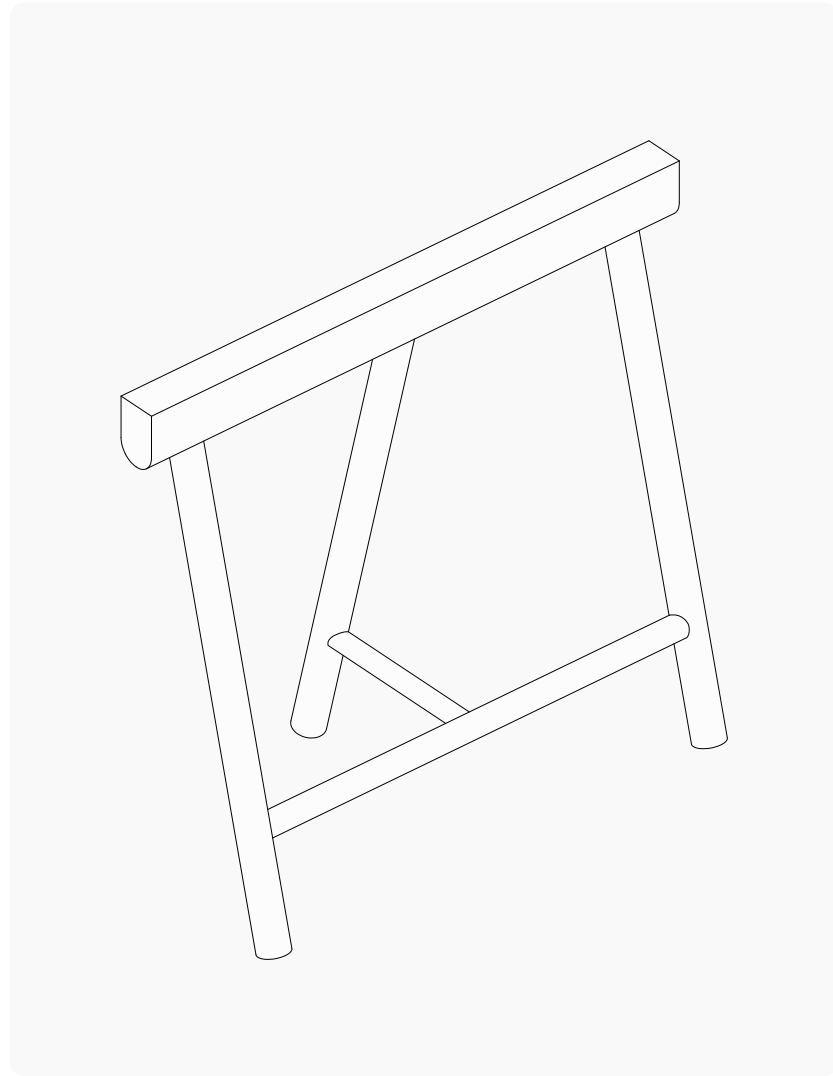



Pinned Trestle Table



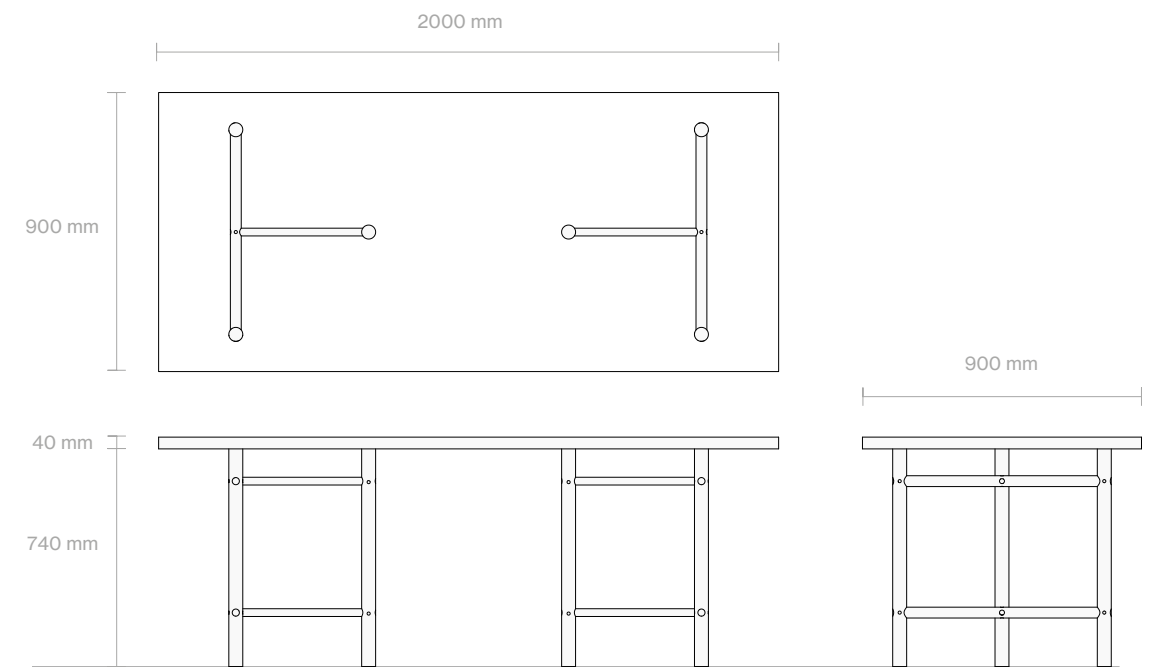

Specifications

**Material
& Finish**

Top

Finish

Teak ————— Oiled/ Sealed
Rosewood ————— Oiled/ Sealed

Legs

Teak ————— Oiled / Sealed
Rosewood ————— Oiled / Sealed

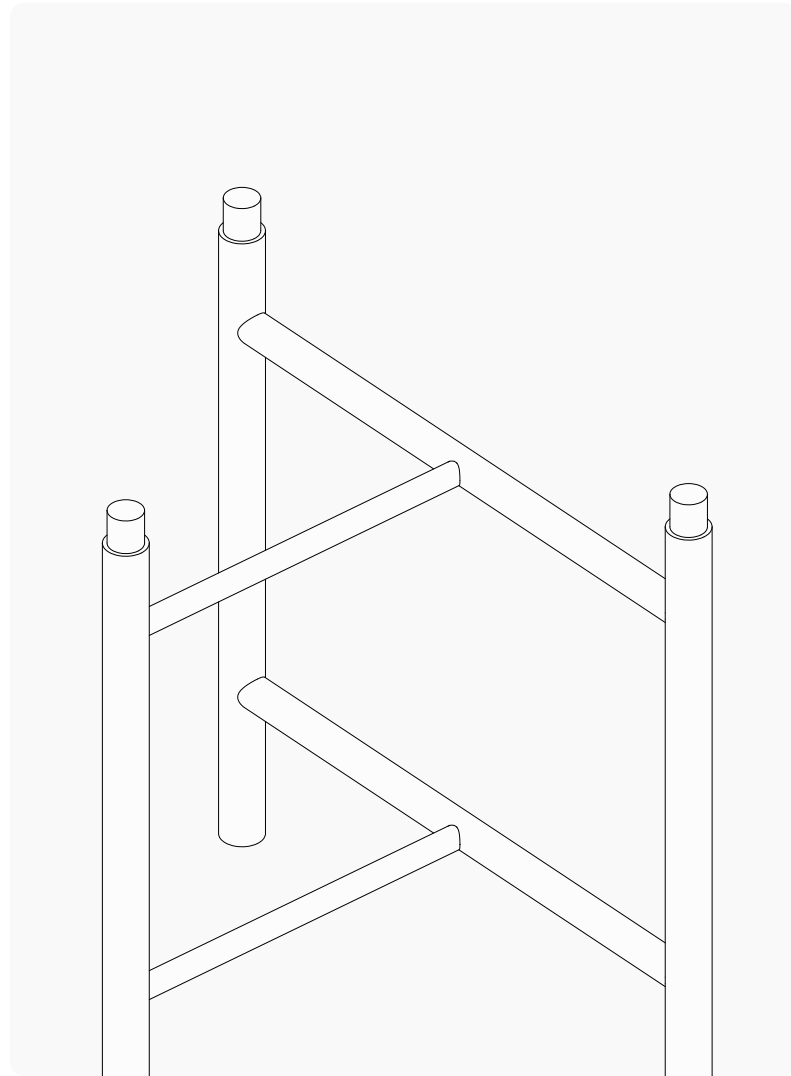



Right Triangle Table



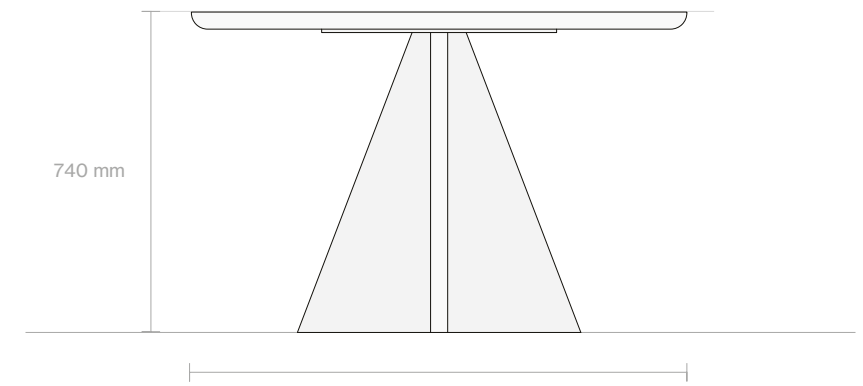
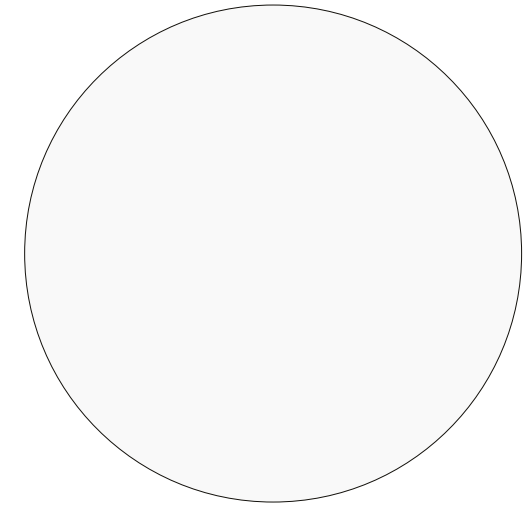
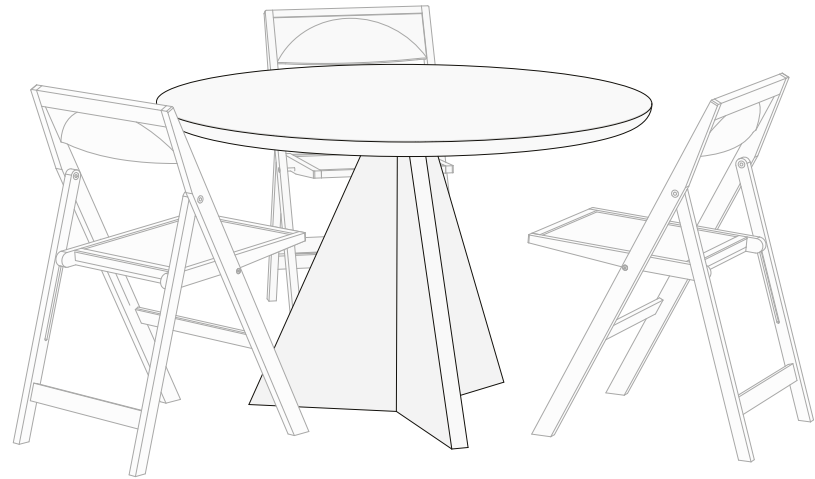

Size 1

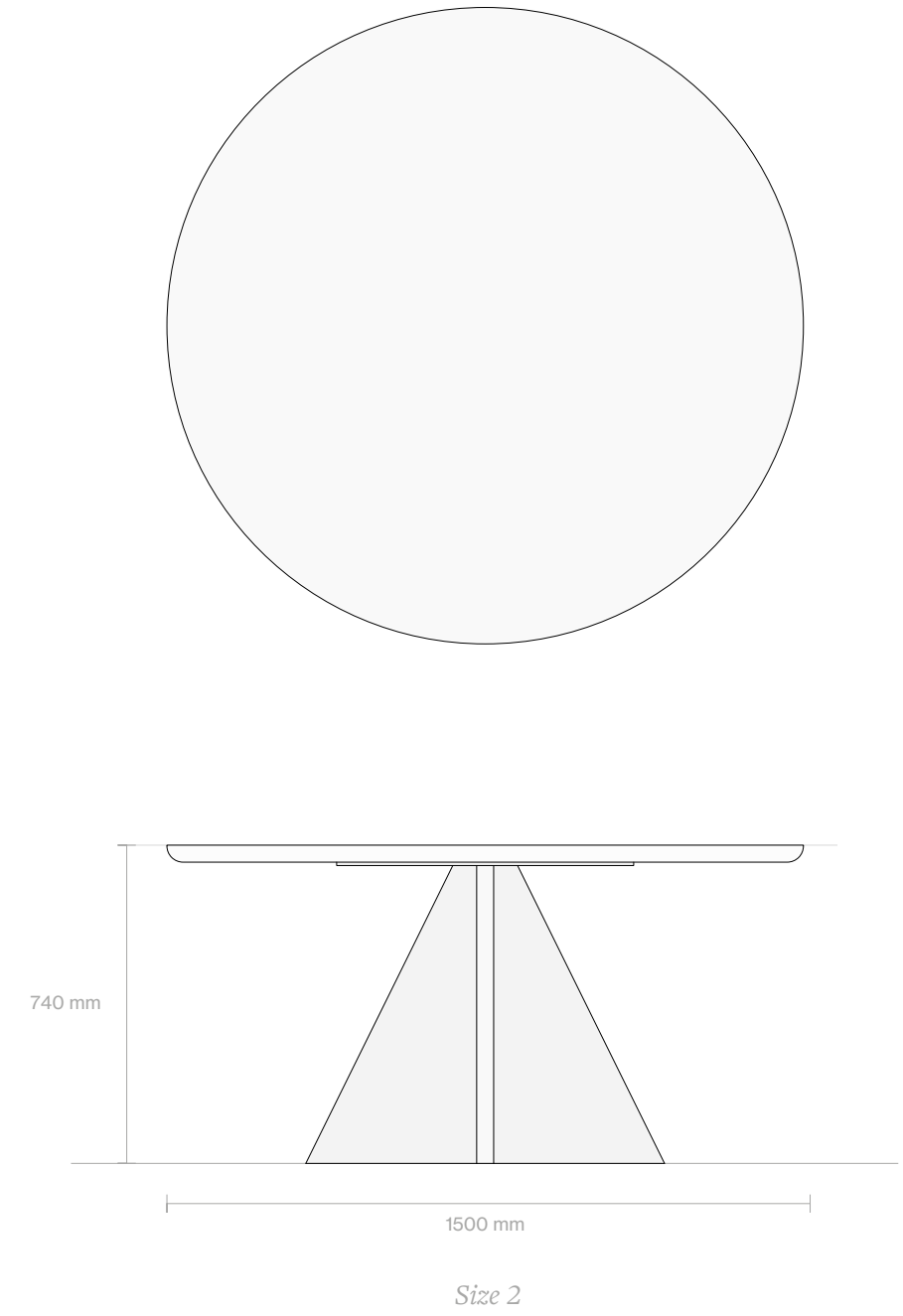
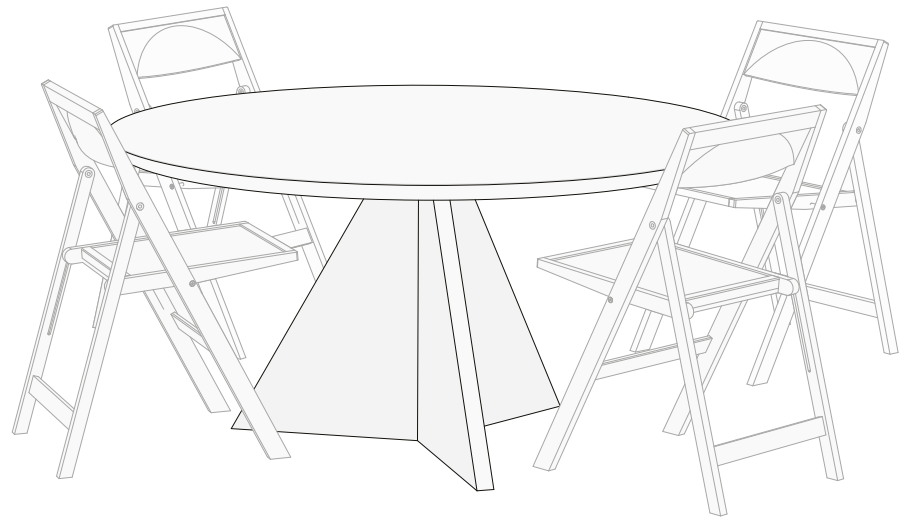

Specifications

**Material
& Finish**

Top

Finish

| | | |
|--------------|-------|---------------|
| Teak | ————— | Oiled/ Sealed |
| Rosewood | ————— | Oiled/ Sealed |
| Pink Marble | ————— | Natural |
| White Marble | ————— | Natural |
| Green Marble | ————— | Natural |

Legs

| | | |
|----------|-------|---------------|
| Teak | ————— | Oiled/ Sealed |
| Rosewood | ————— | Oiled/ Sealed |

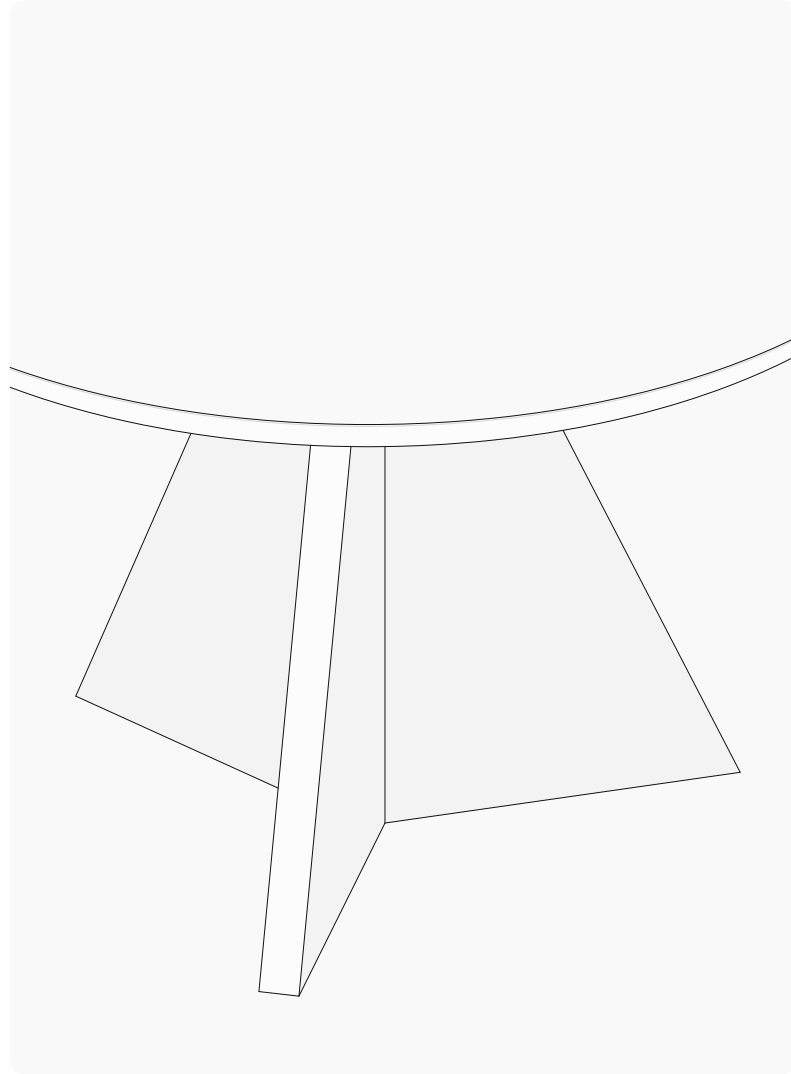



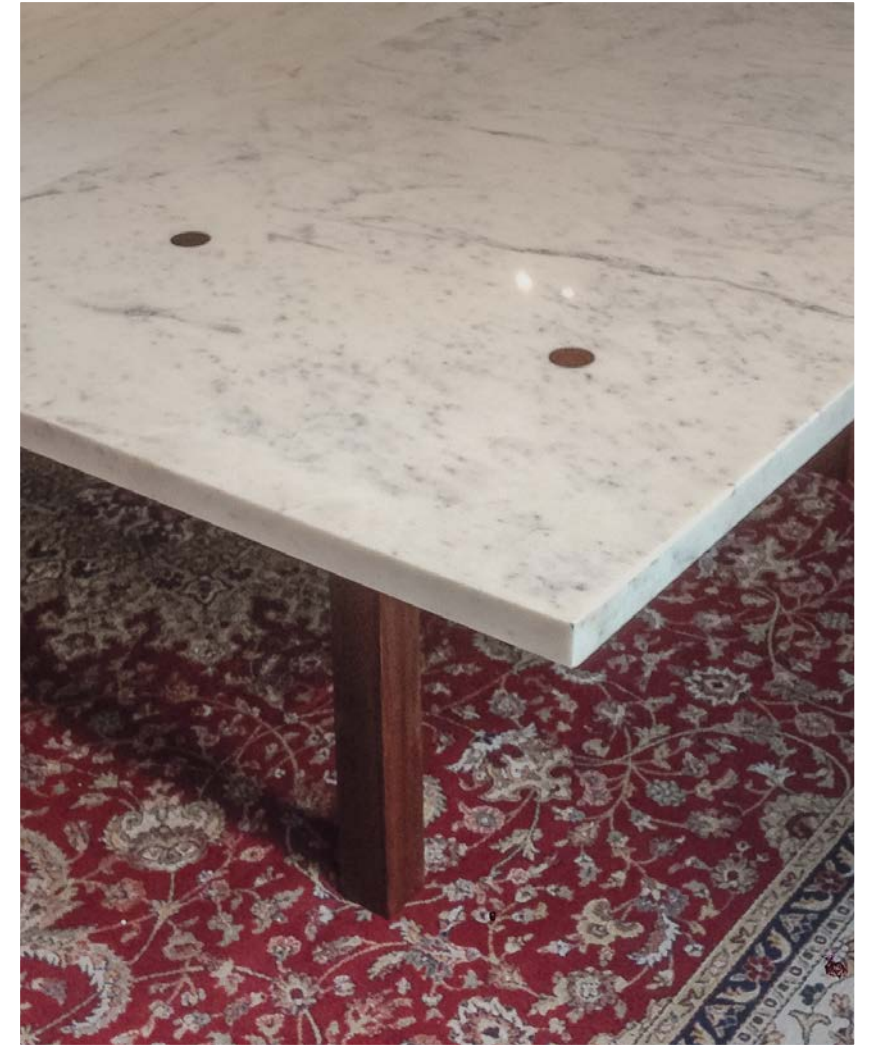

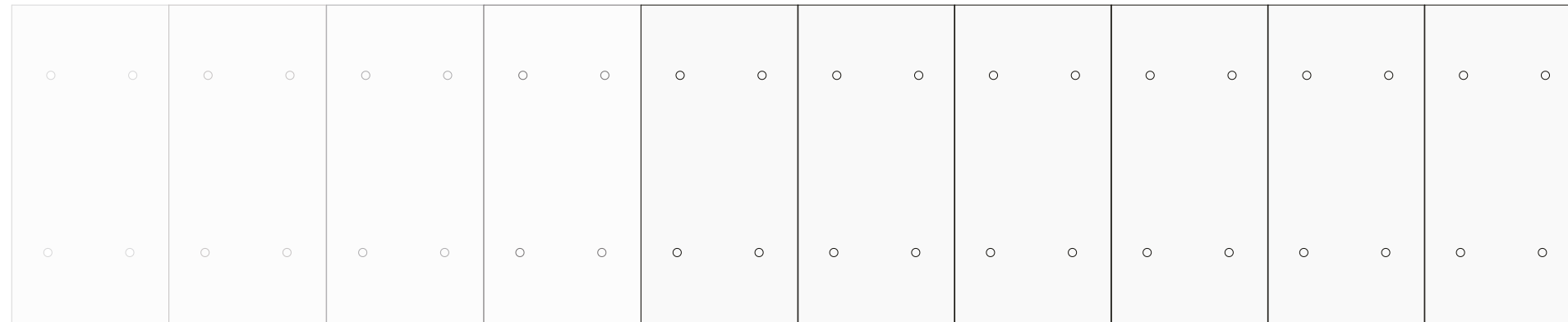
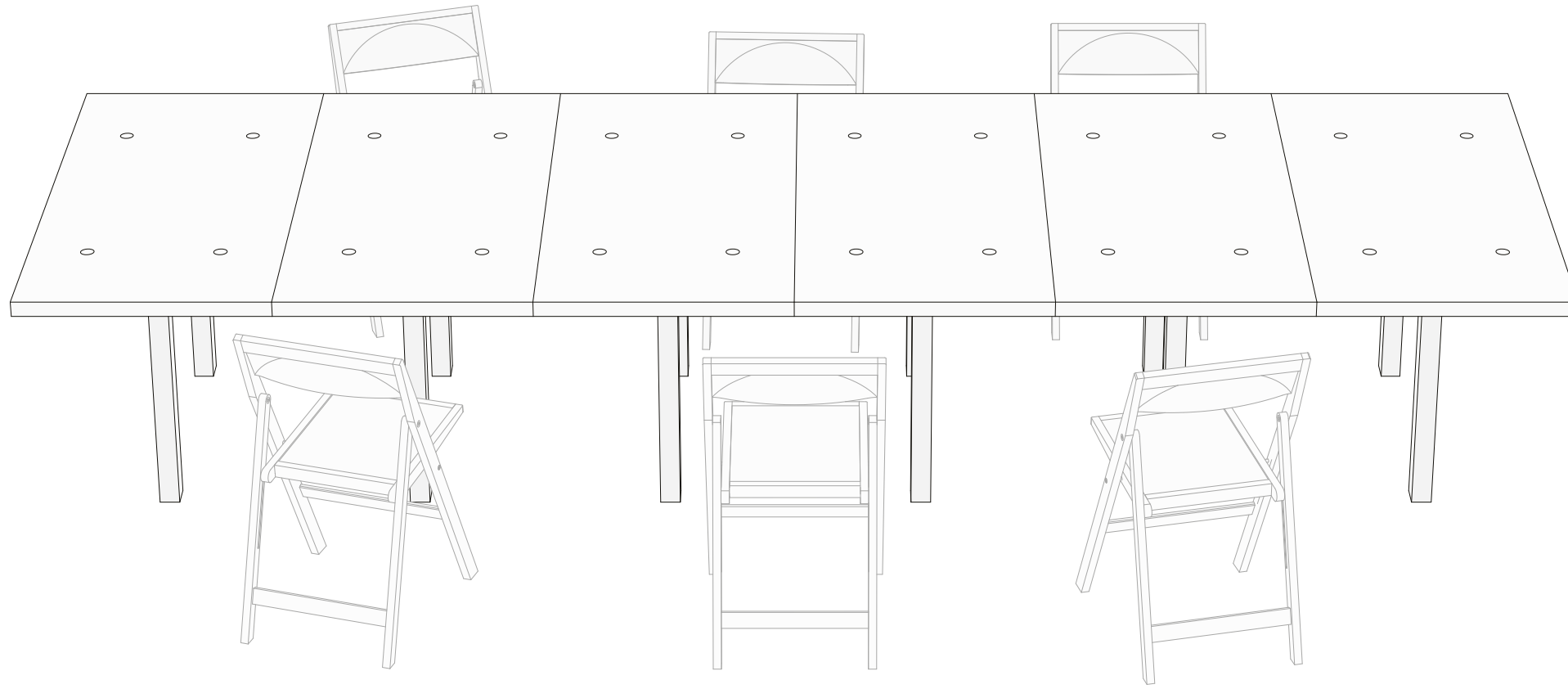

Width can be customized

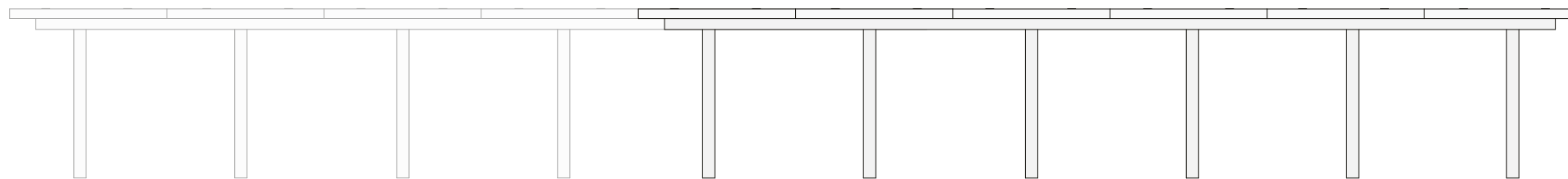

740 mm



Length of this table can be customized

Specifications

**Material
& Finish**

Top

Finish

White Marble

Natural

Legs

Teak

Oiled/ Sealed

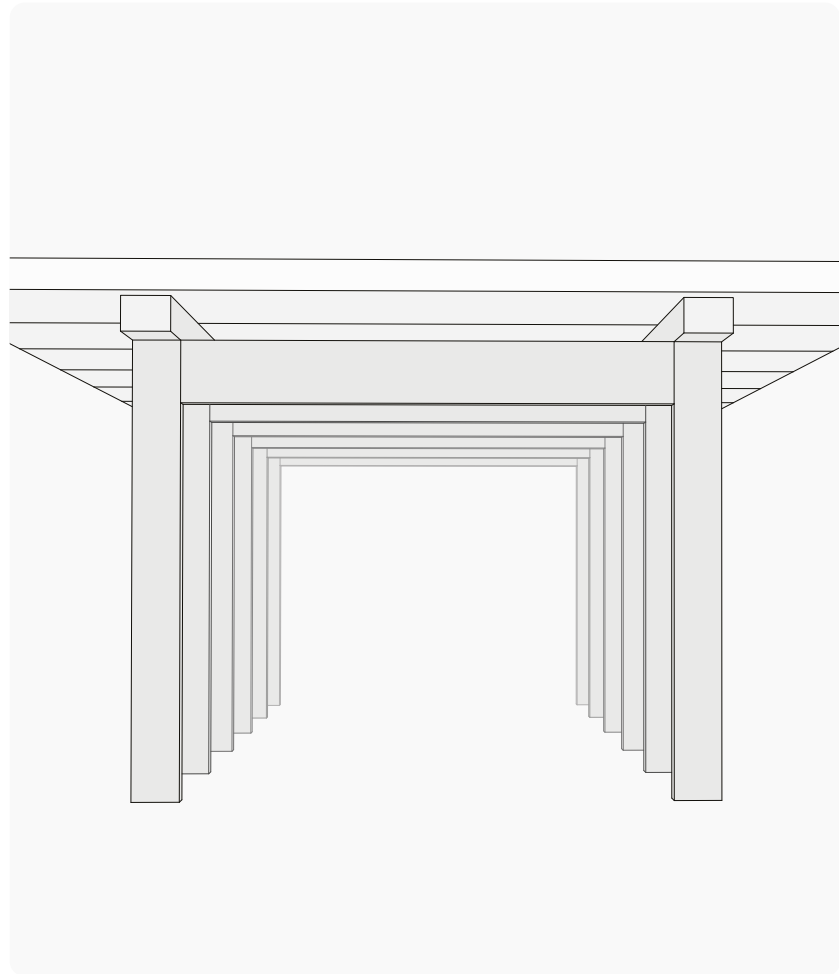

Three Cylinder Table





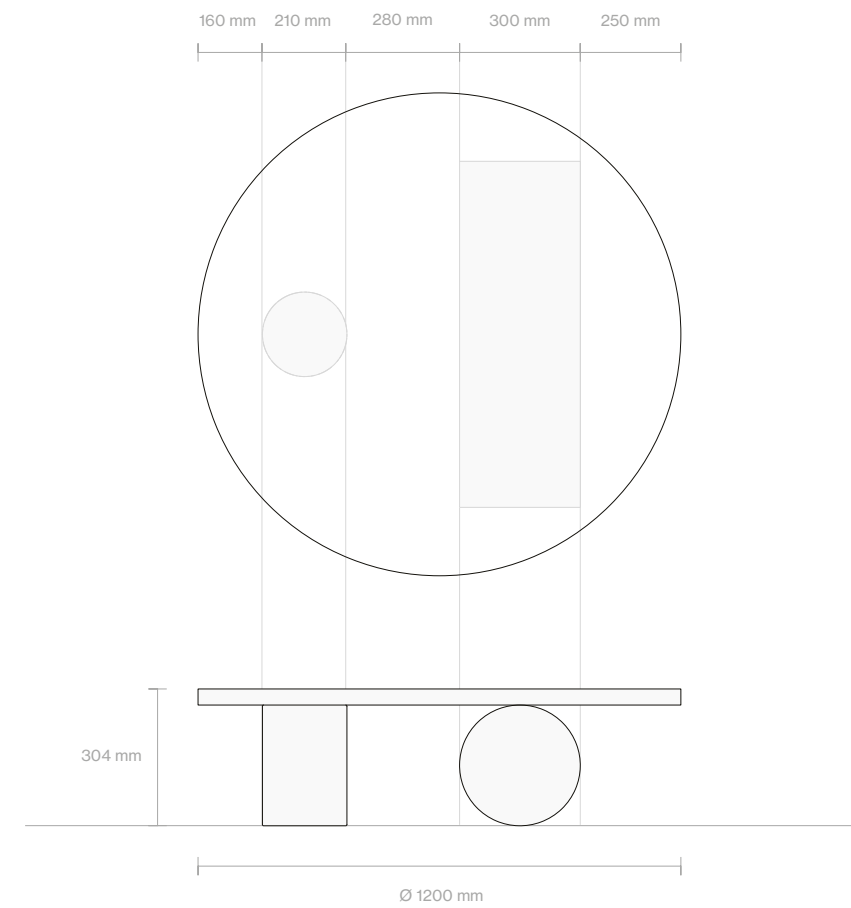
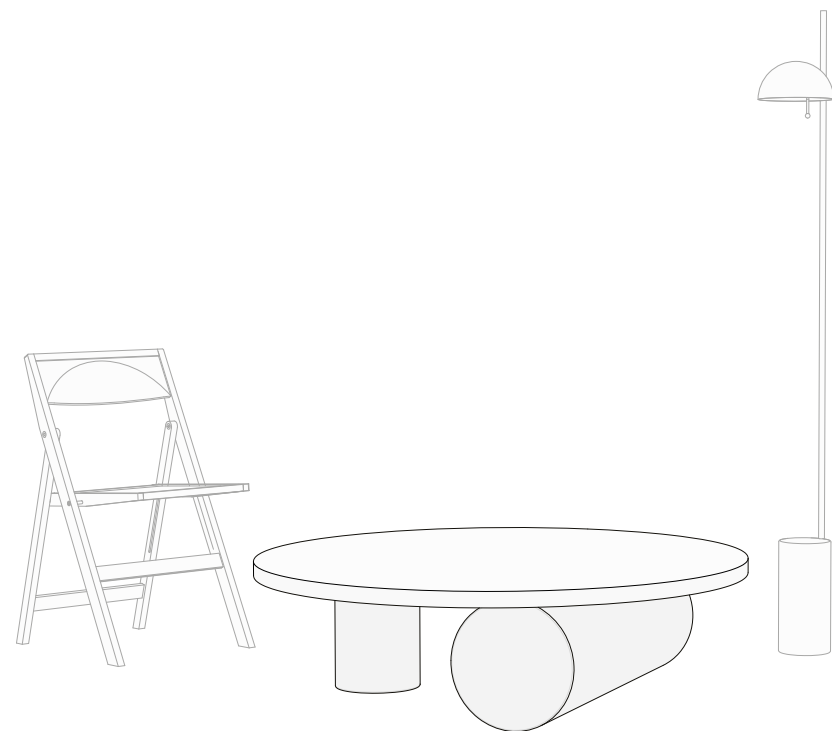

1200 mm

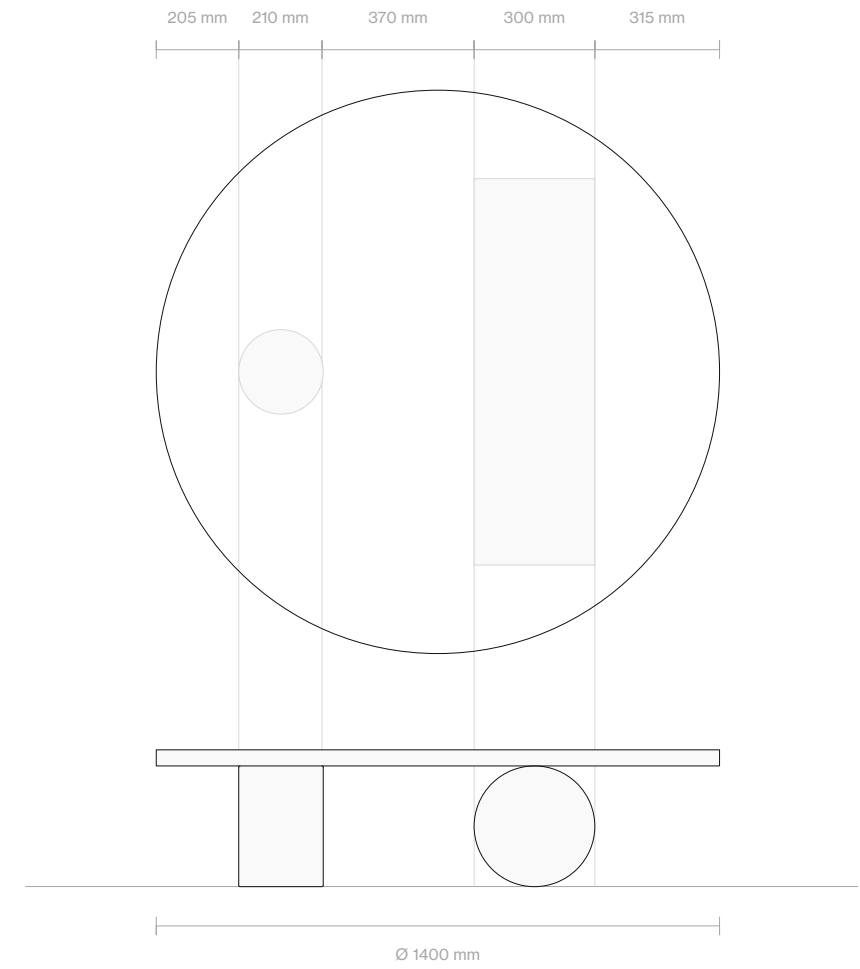
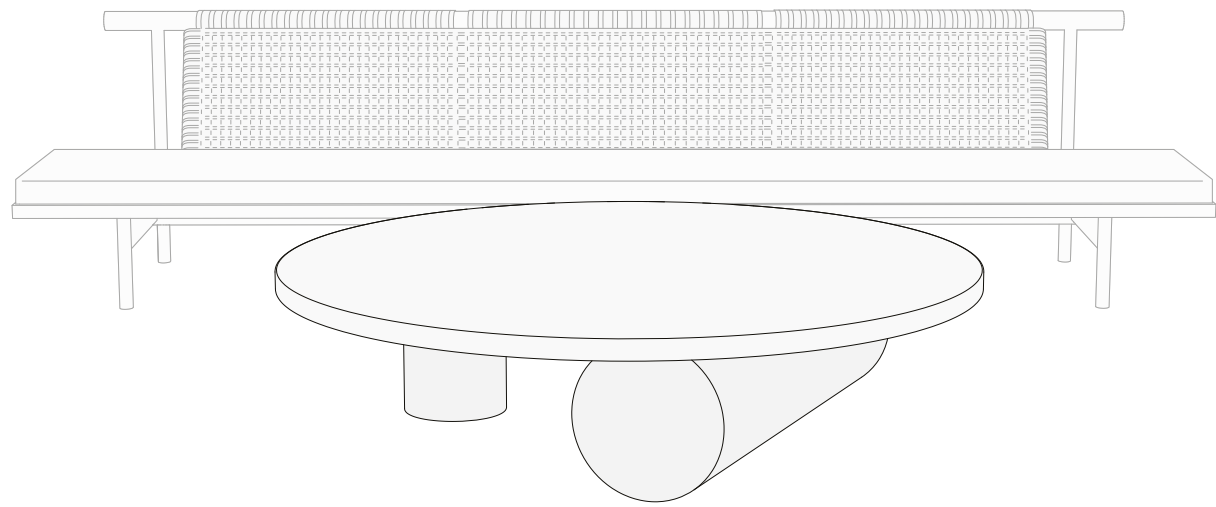

1400 mm

Specifications

**Material
& Finish**

Body

Finish

| | | |
|--------------|-------|----------|
| Terrazzo | ————— | Polished |
| White Marble | ————— | Polished |
| Pink Marble | ————— | Polished |
| Black Marble | ————— | Polished |
| Green Marble | ————— | Polished |

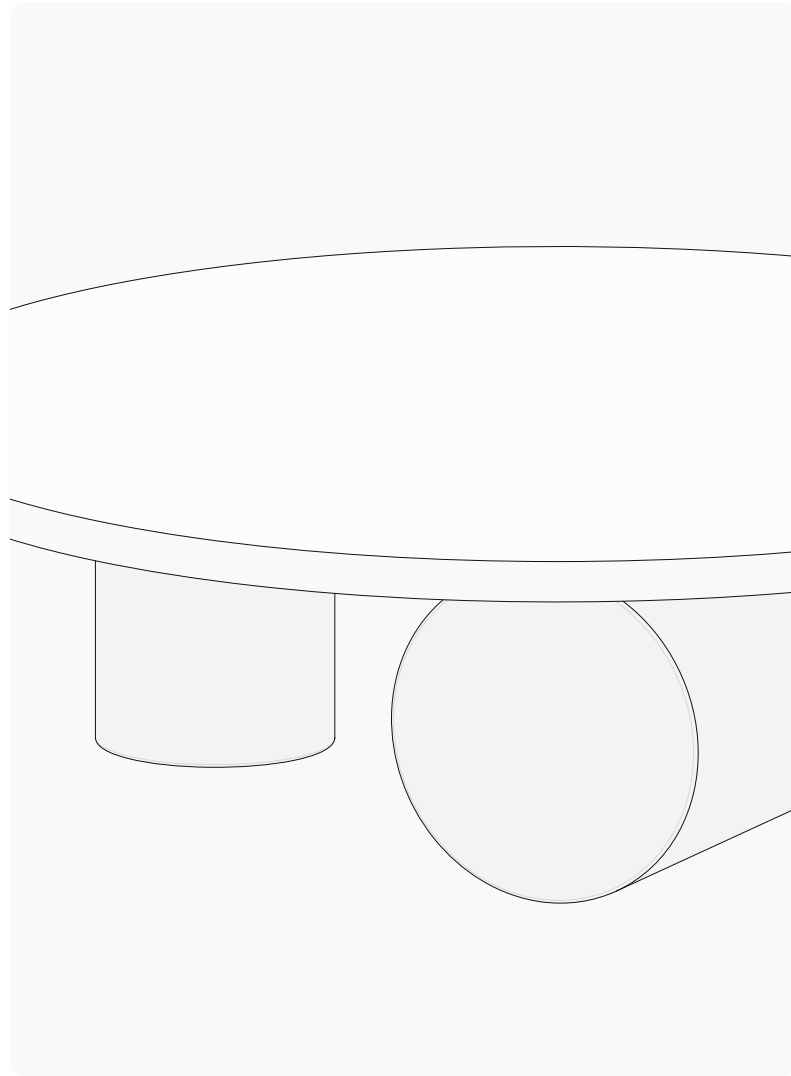

Three Leg Table





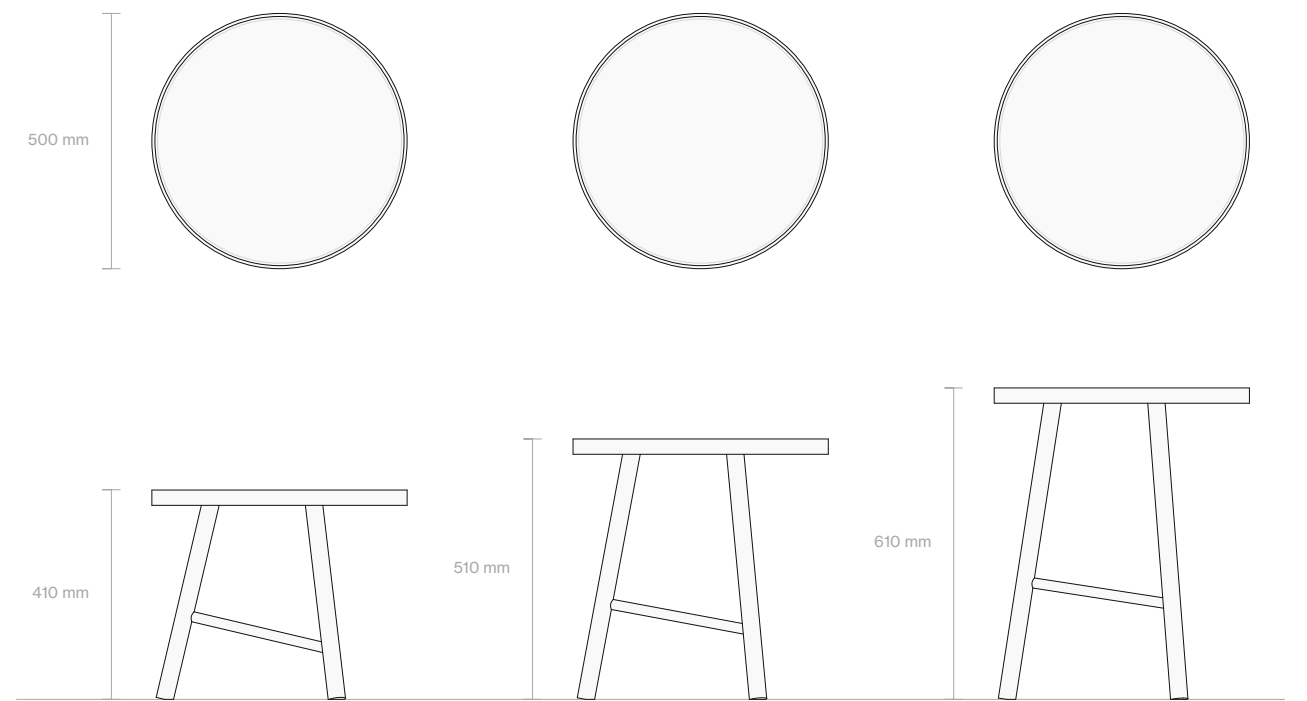
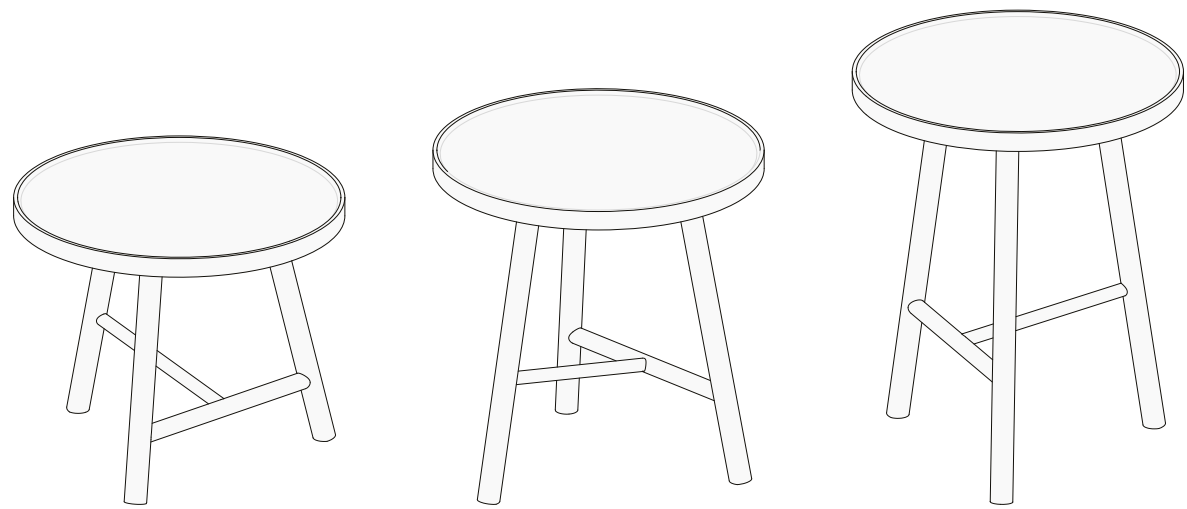

Specifications

**Material
& Finish**

Top

Finish

| | | |
|--------------|-------|---------------|
| Teak | _____ | Oiled/ Sealed |
| Rosewood | _____ | Oiled/ Sealed |
| Grey Stone | _____ | Natural |
| White Marble | _____ | Natural |

Legs

| | | |
|----------|-------|---------------|
| Teak | _____ | Oiled/ Sealed |
| Rosewood | _____ | Oiled/ Sealed |



Profiled Stone Console



Specifications

**Material
& Finish**

Top

Finish

Sandstone

Leather

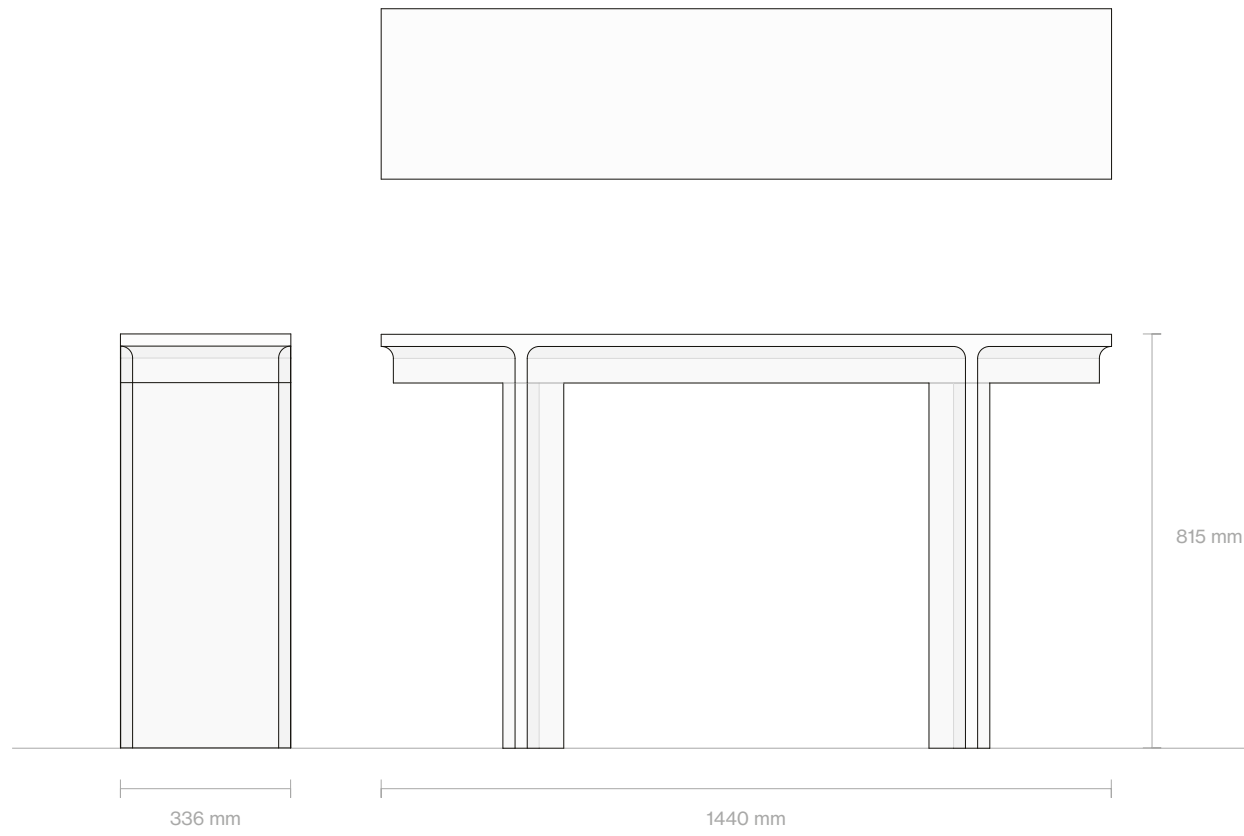

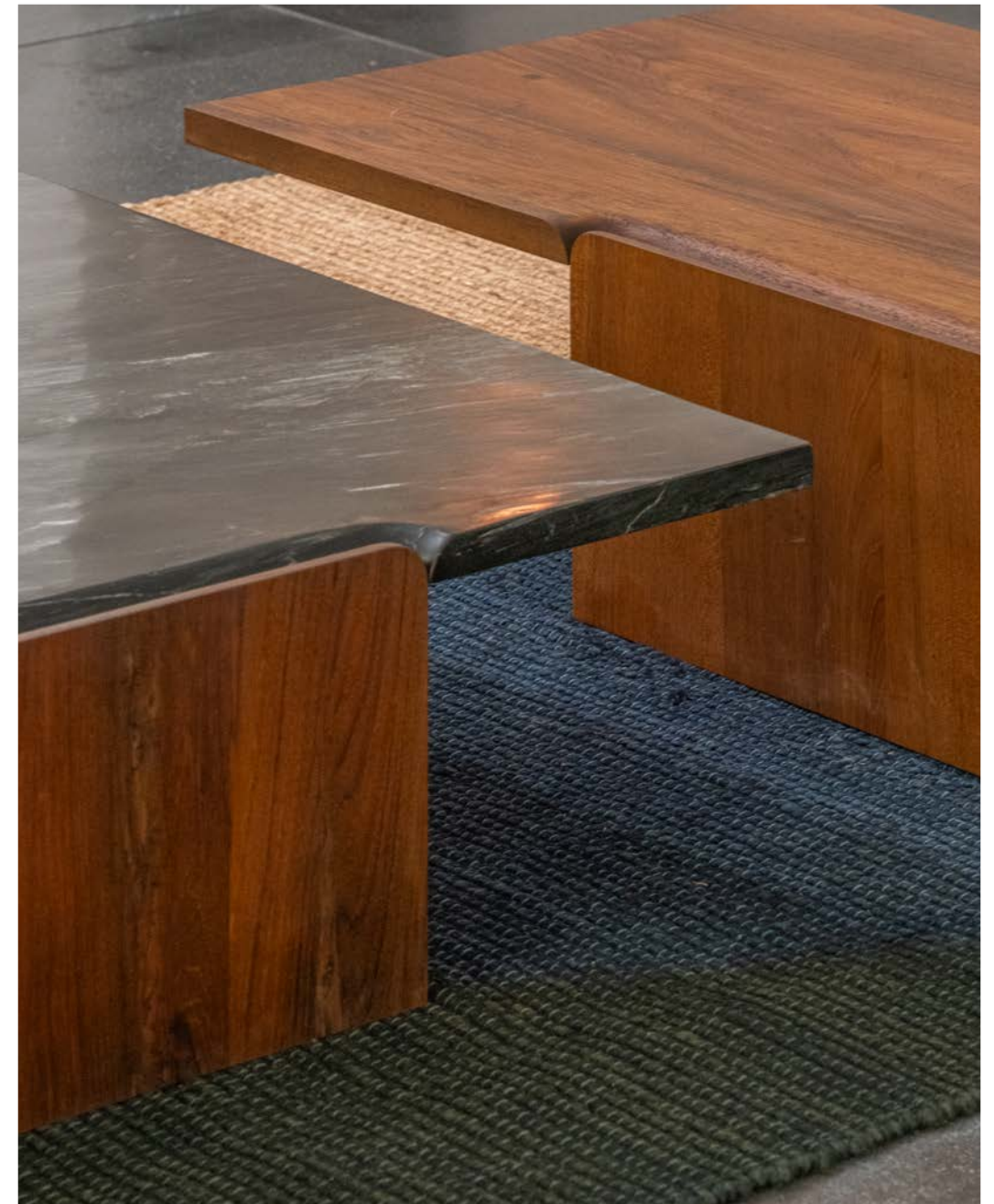

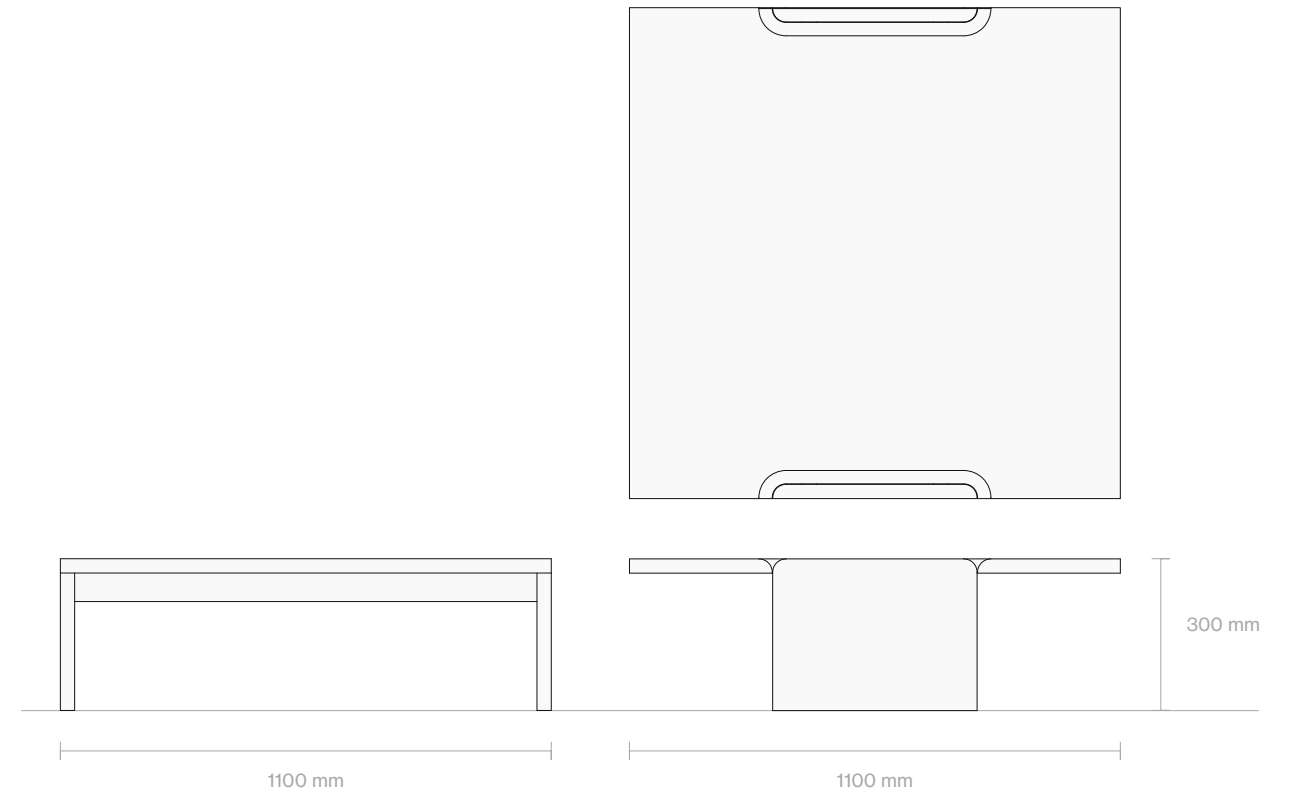
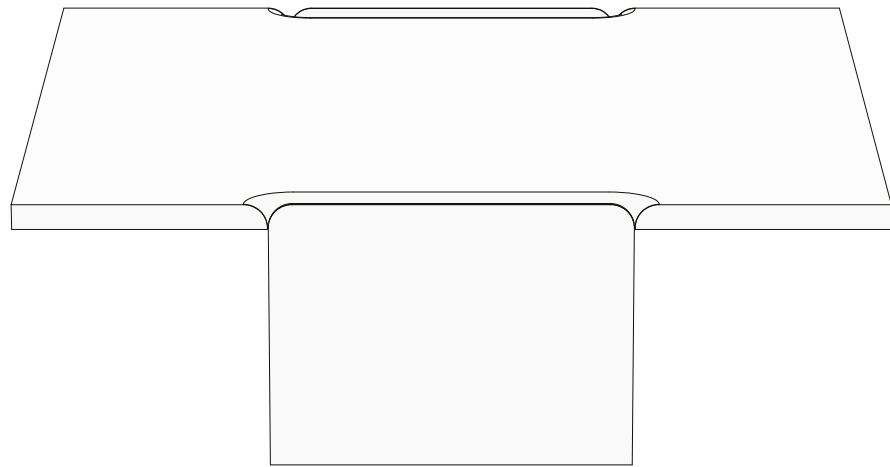

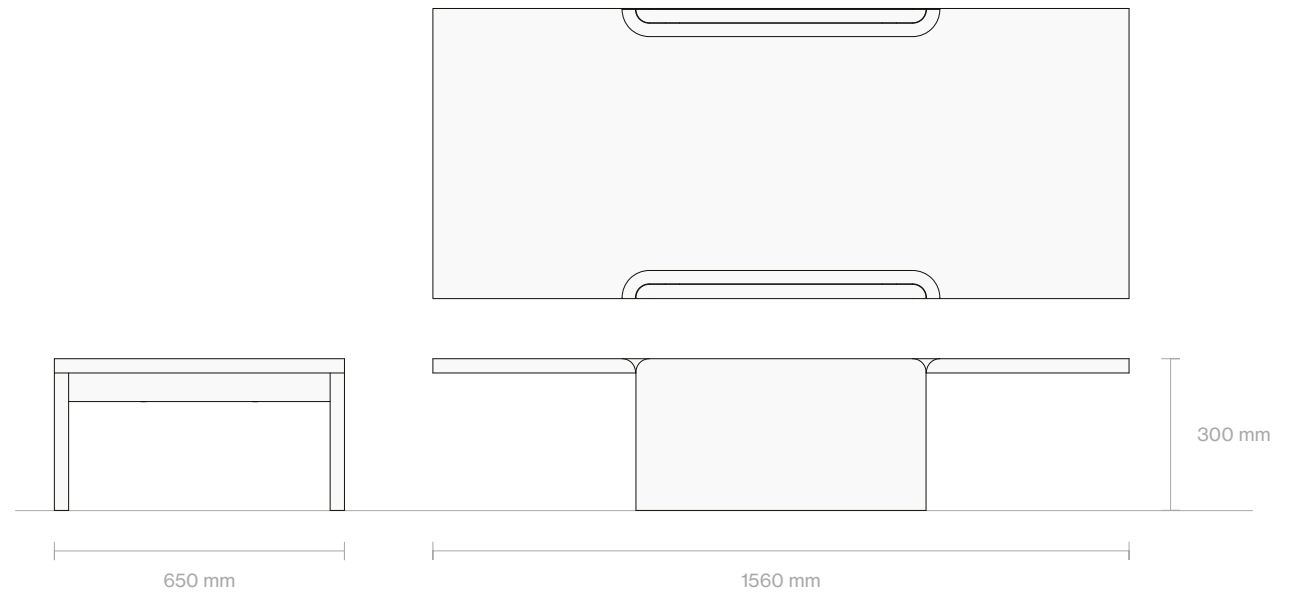

Specifications

**Material
& Finish**

Top

Finish

Teak ————— Oiled
Black Marble ————— Polished

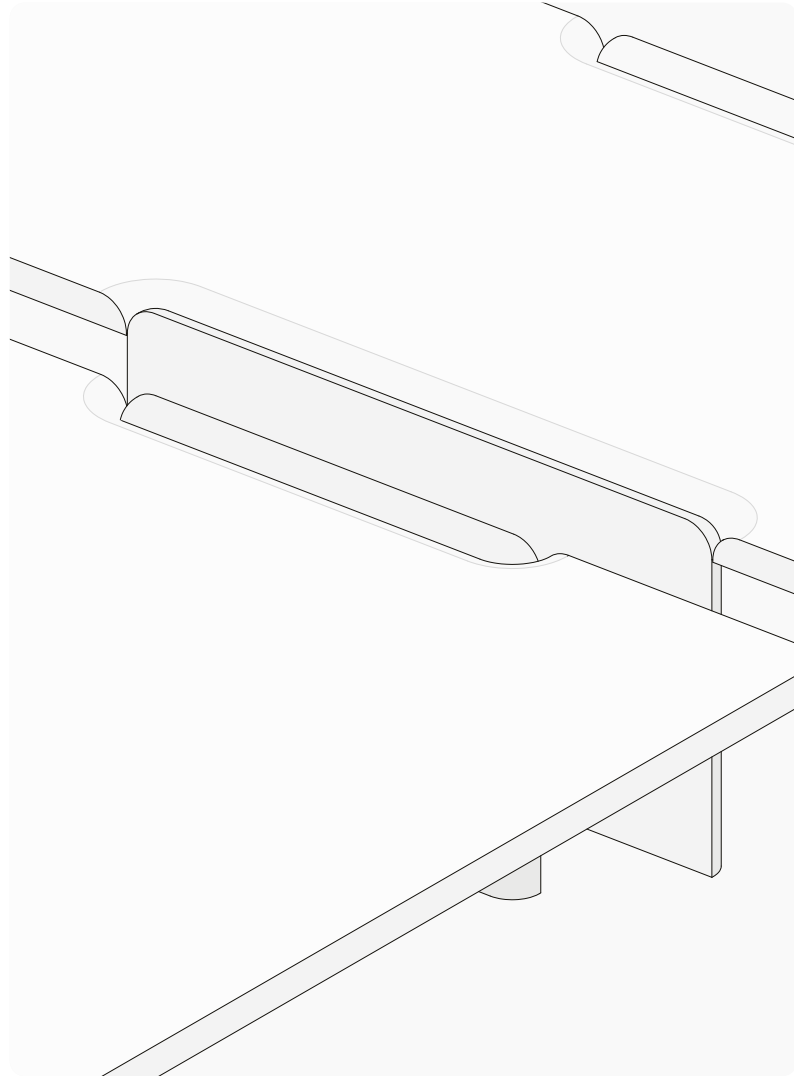

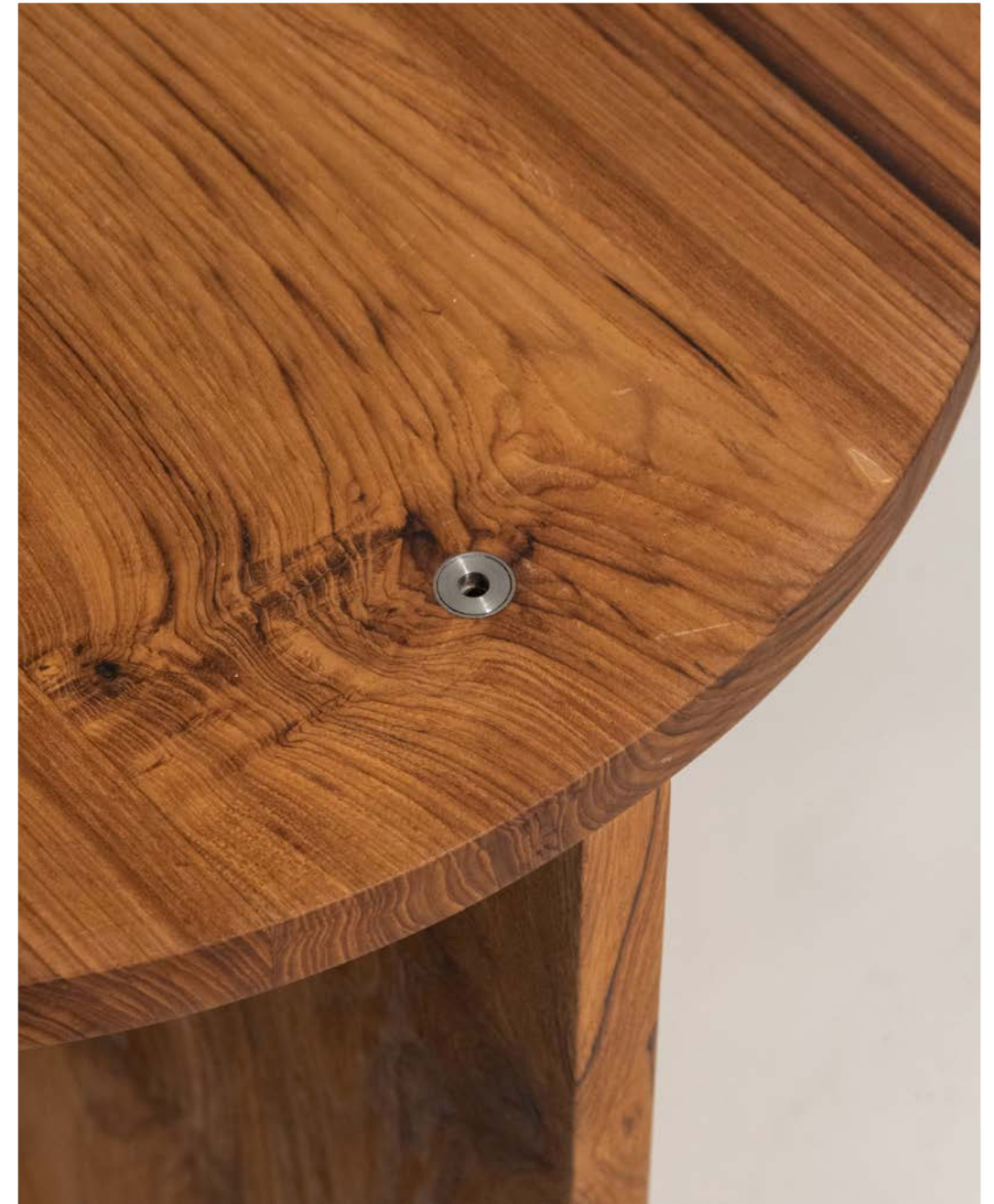

Specifications

**Material
& Finish**

Body

Finish

| | | |
|----------|-------|-----------|
| Teak | ————— | Oiled |
| Teak | ————— | Blackened |
| Rosewood | ————— | Oiled |

Hardware

Stainless Steel

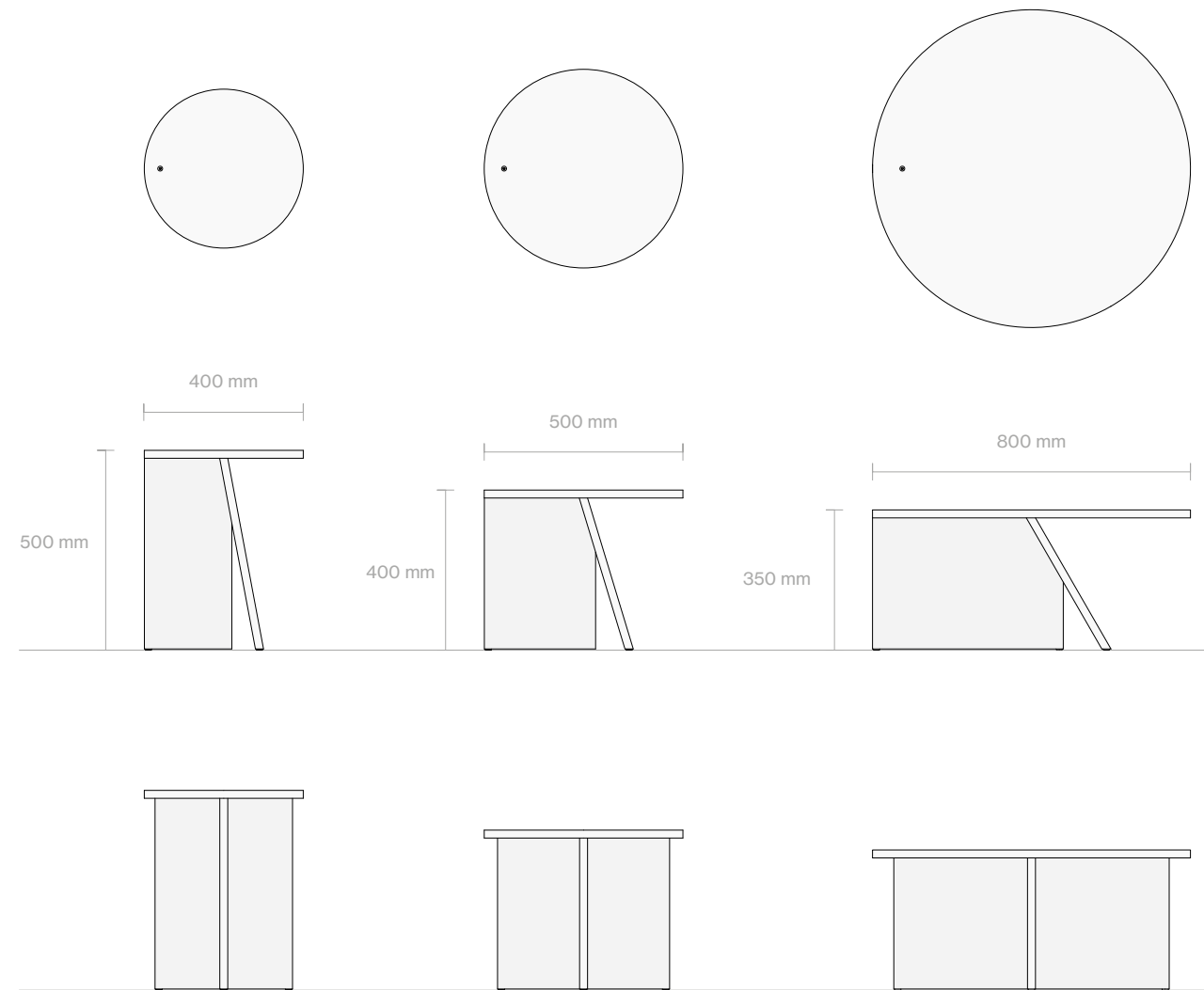

Truncated Pyramid Table



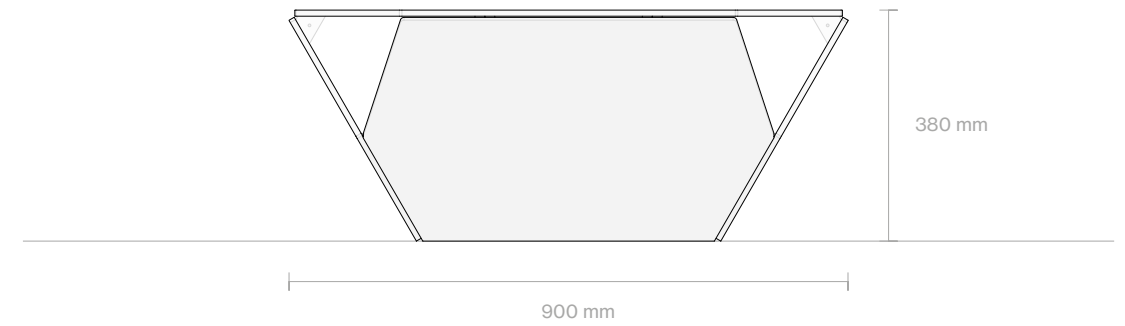
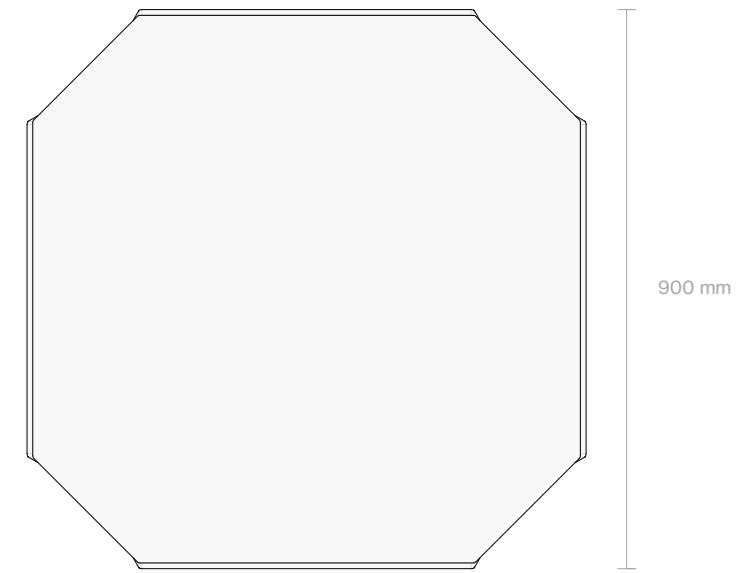
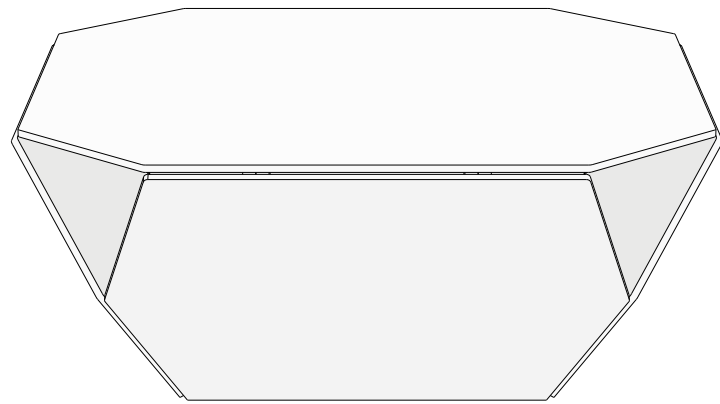

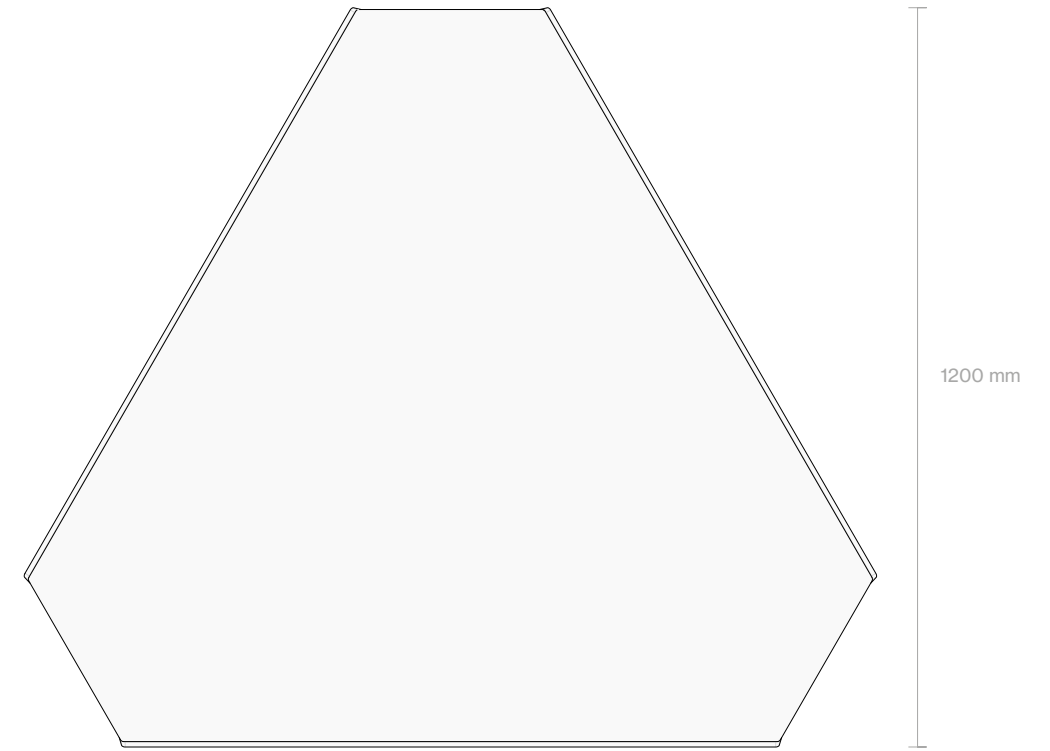
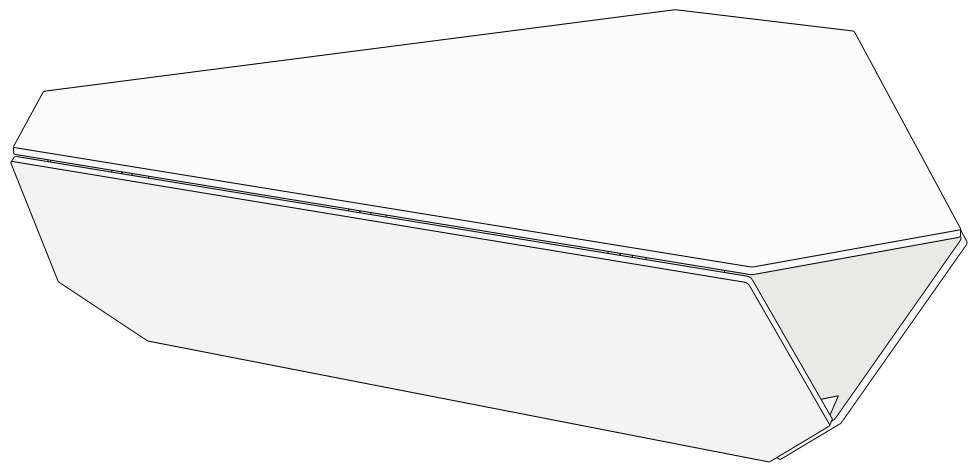

Specifications

**Material
& Finish**

Body

Finish

Aluminium ————— Neutral Anodised
Aluminium ————— Black Anodised

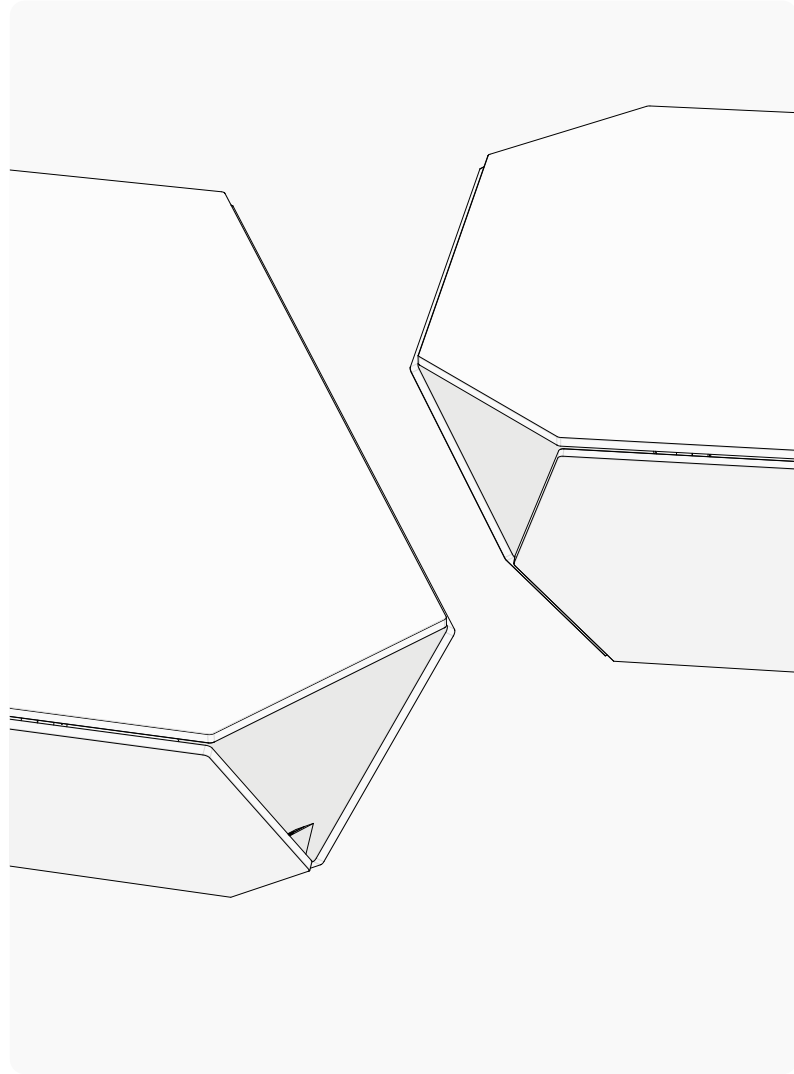

Woven Back Chair





Specifications

Material & Finish

Body

Finish

Teak ————— Oiled

Back rest

Cotton Rope
Recycled Rope

Seat Upholstery

Standard Cotton ¹
Fabric by *Leel* ²

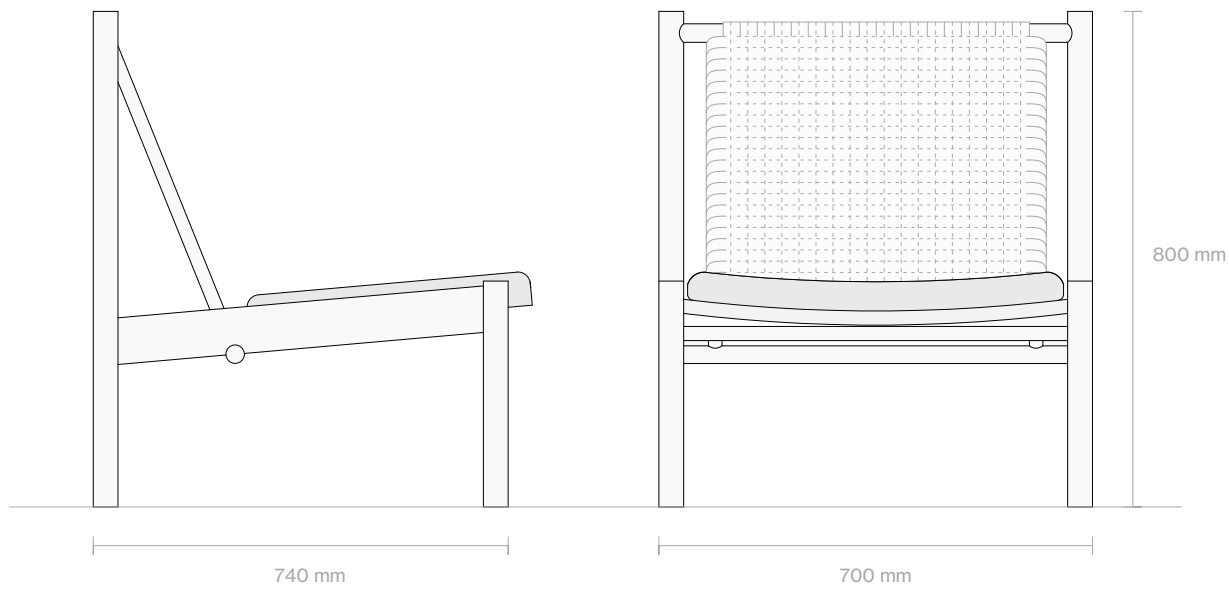
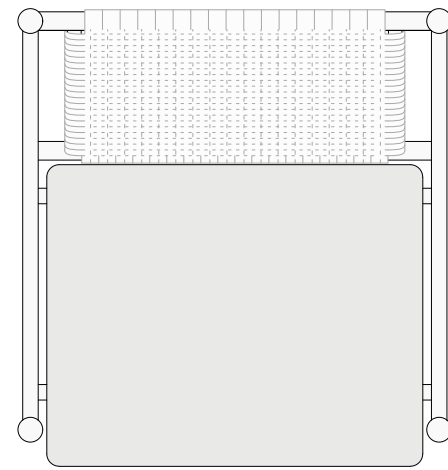

1 Colours can be customised.

2 *Leel* is a sustainable practice deeply rooted in the development of hand crafted textiles and techniques.

Note Customizing materials, including colours and fabrics for cushions may require additional production time.

Splayed Plank Table & Bench





Specifications

**Material
& Finish**

Body

Finish

Teak

Oiled

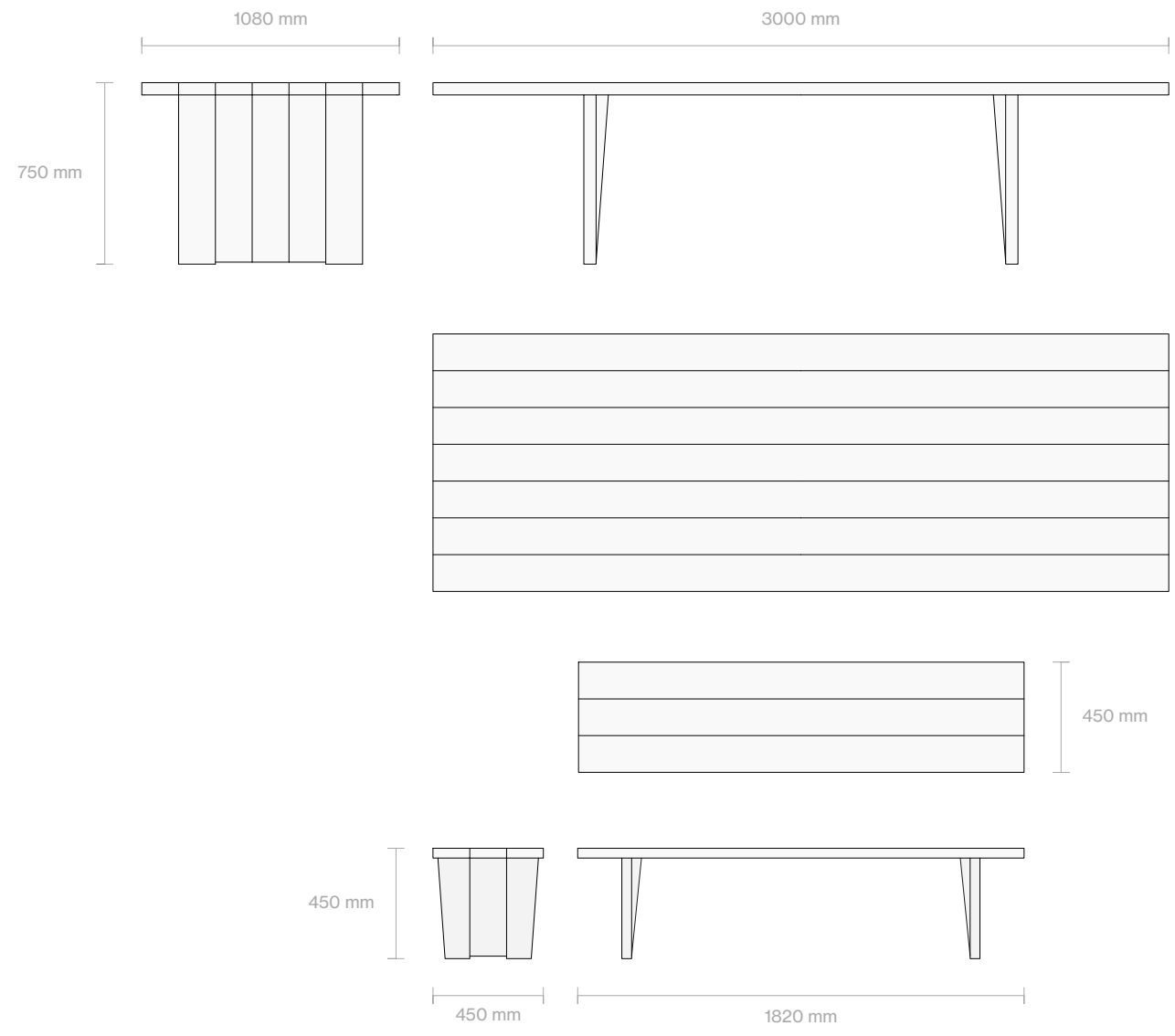



Front Facing Light





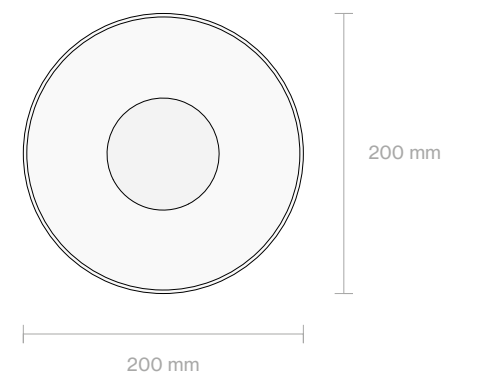
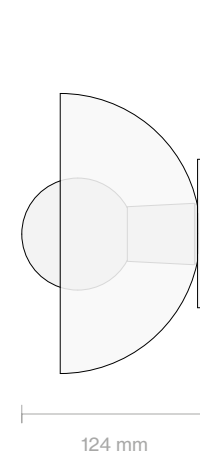
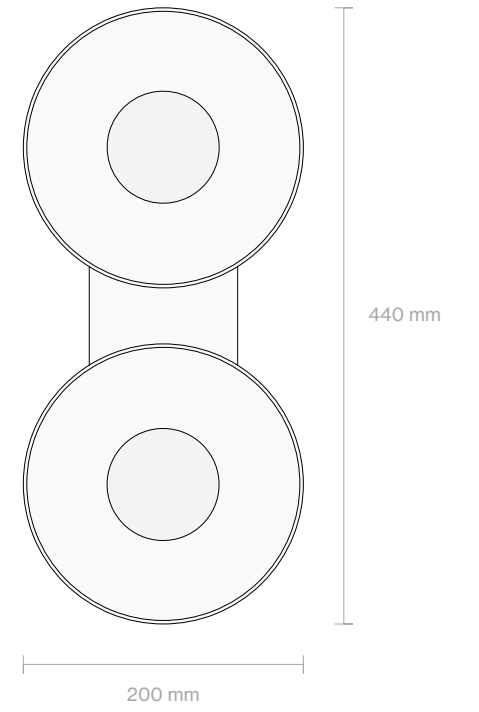
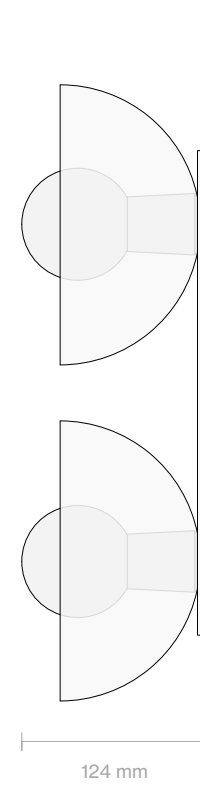
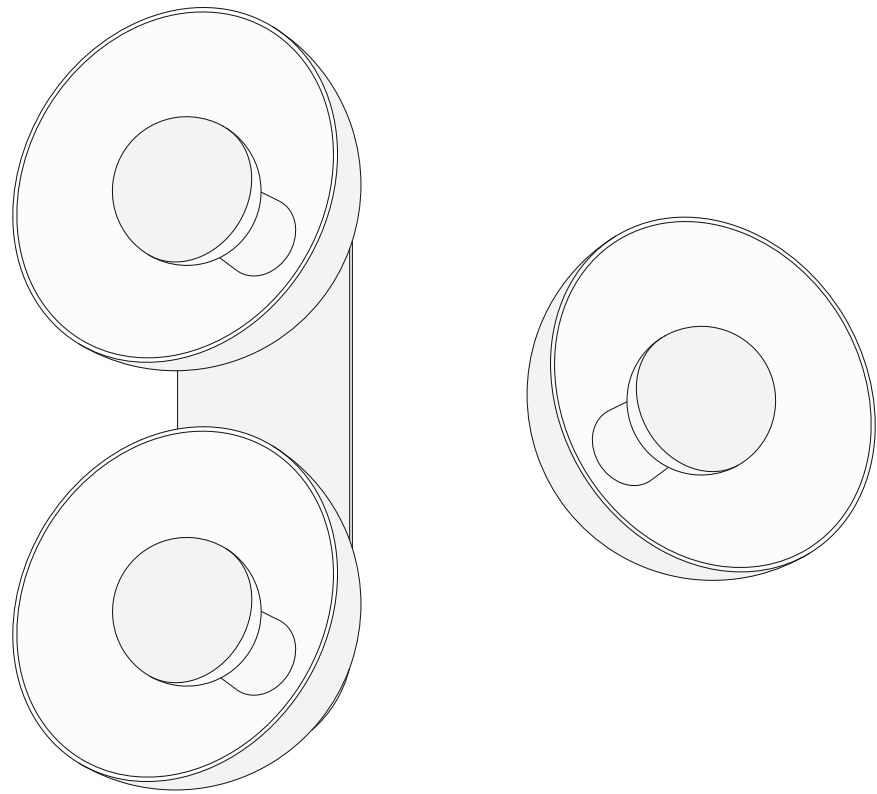

Specifications

**Material
& Finish**

Body

Finish

| | | |
|---------------|-------|-----------------|
| Nickel Plated | ————— | Stainless Steel |
| Brass | ————— | Aged, Blackened |

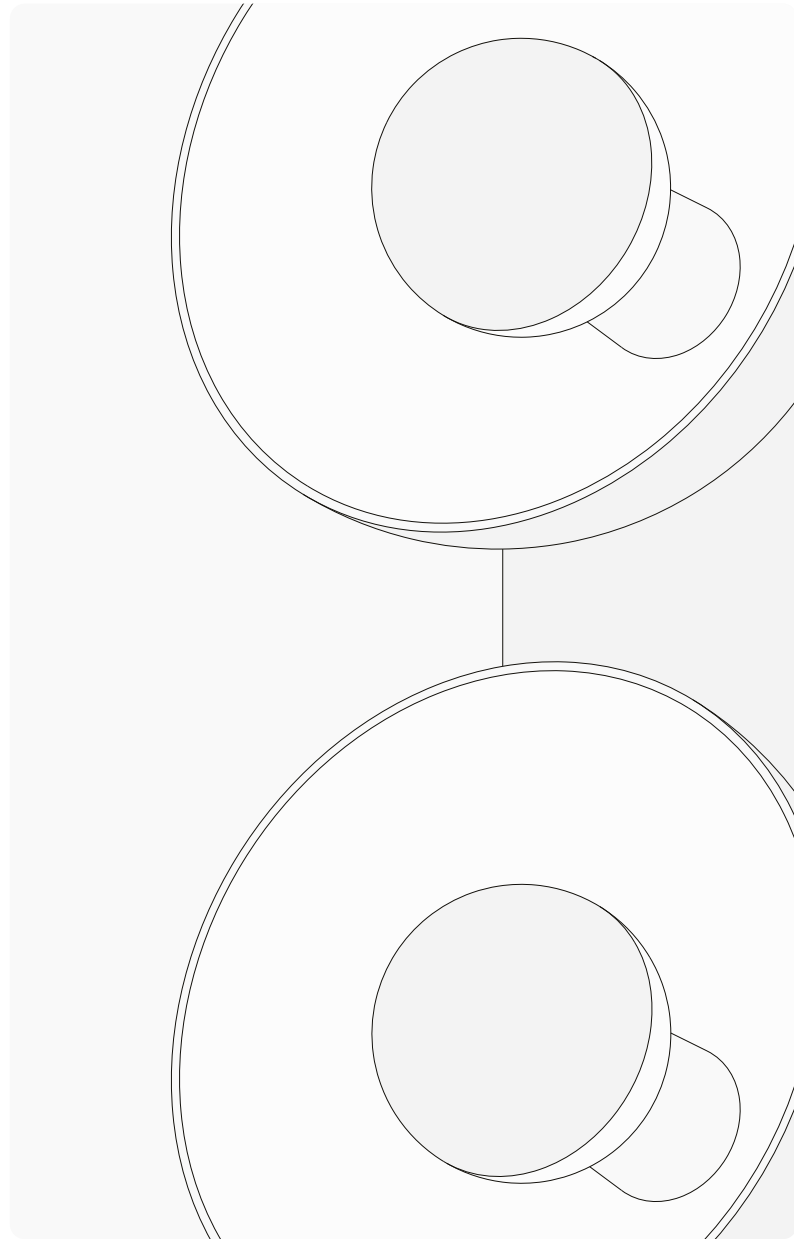

**Electrical
Specifications**

Light

Neptune lights Classic Bulb G80
- 4W - 2700k - Reflector - E27 -
220V-240V AC



Rolling Round Lights



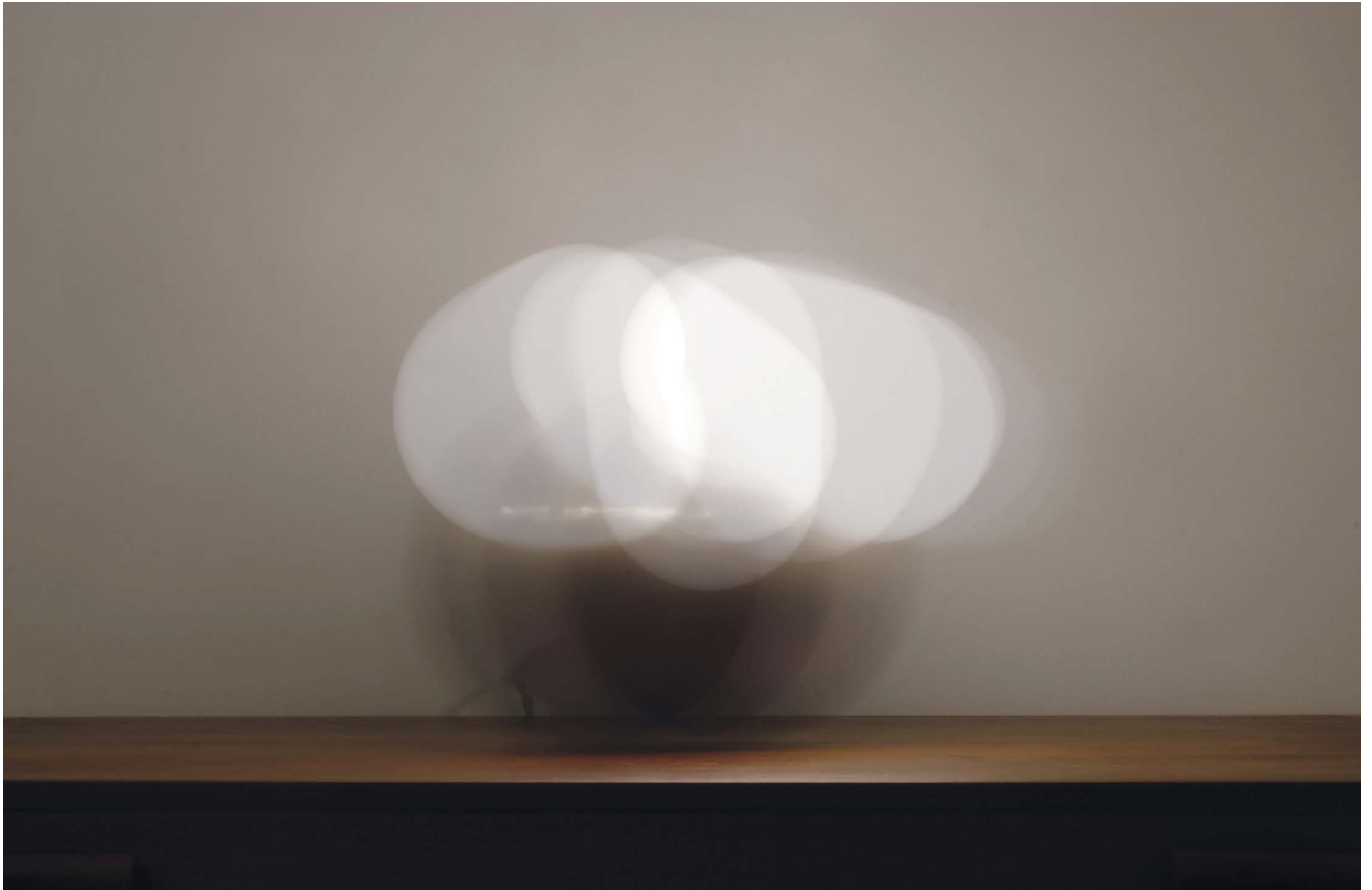

Specifications

**Material
& Finish**

Body

Finish

| | | |
|----------|-------|------------|
| Brass | _____ | Aged/ Dark |
| Rosewood | _____ | Sealed |

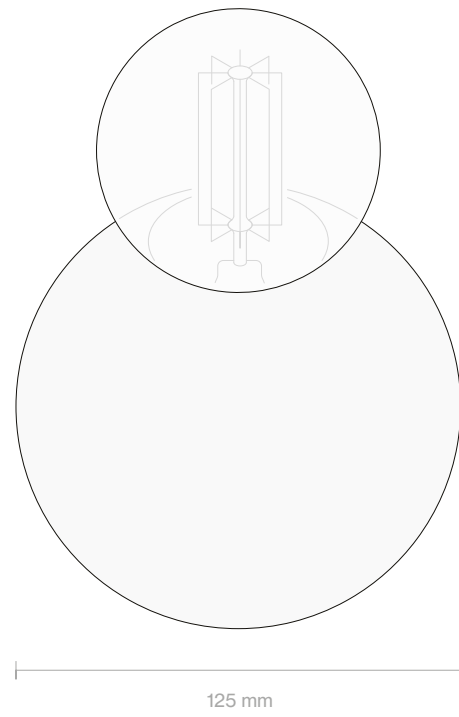
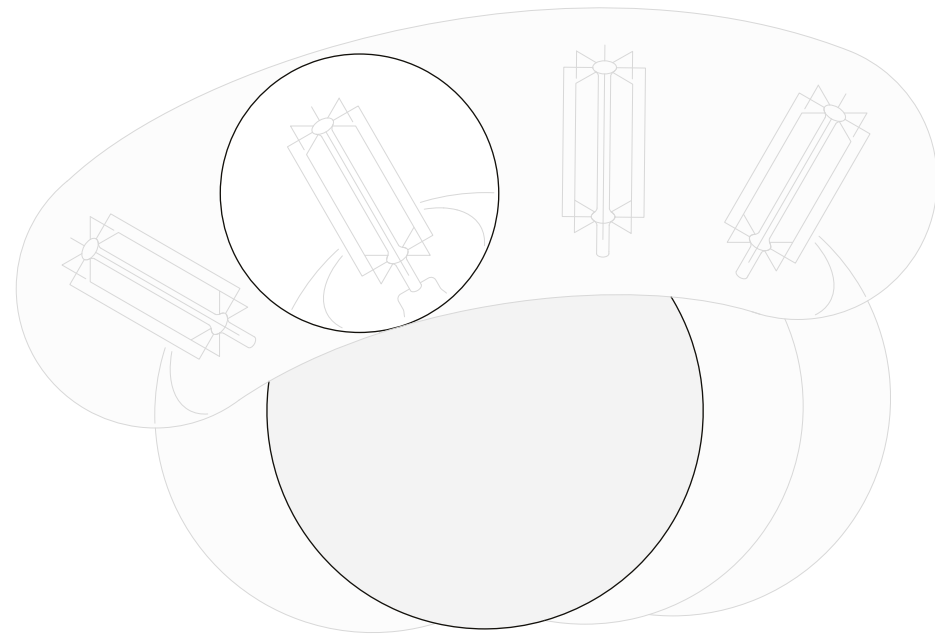

**Electrical
Specifications**

Light

Incandescent Edison type bulb (240V)

Dimmer

For lightbulbs & incandescent bulbs

Plug

Legrand 2p 16A, 220 - 240V

Cord

Snoerberg black cloth cord



Seven Tube Light







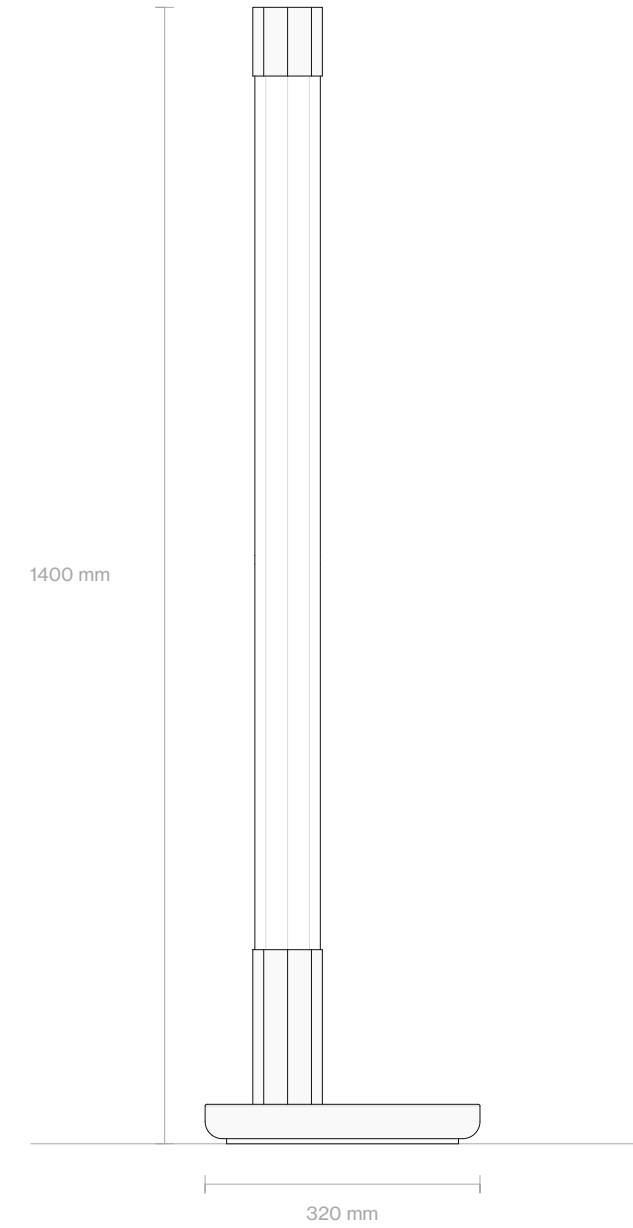
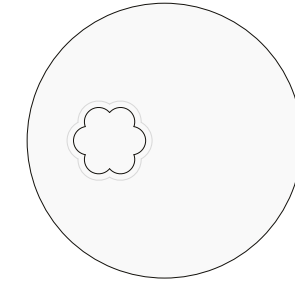
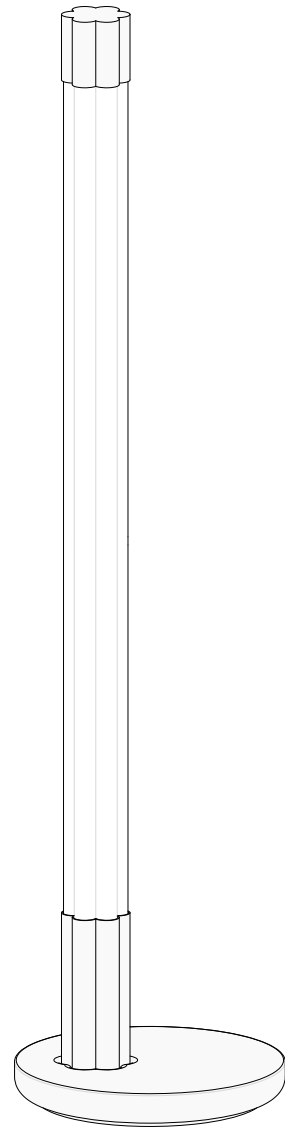

Floor Variant

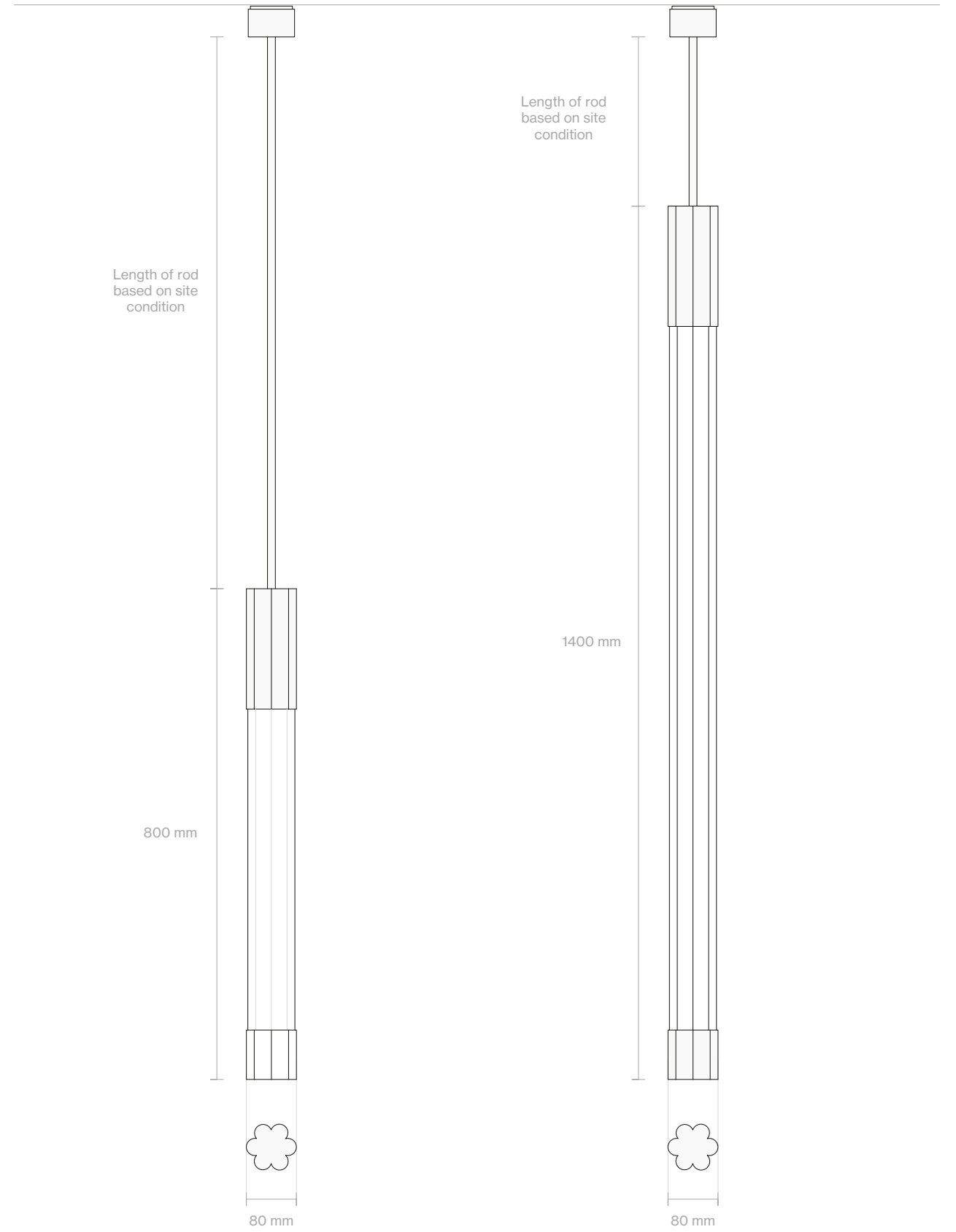
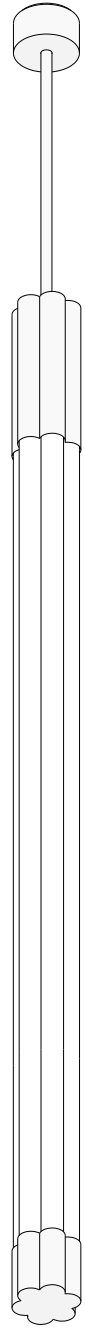
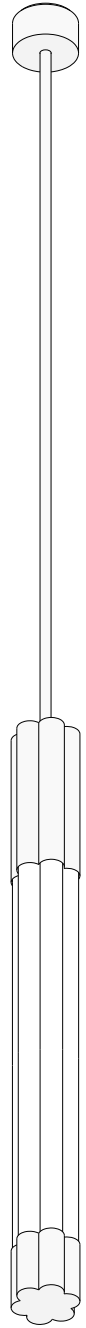

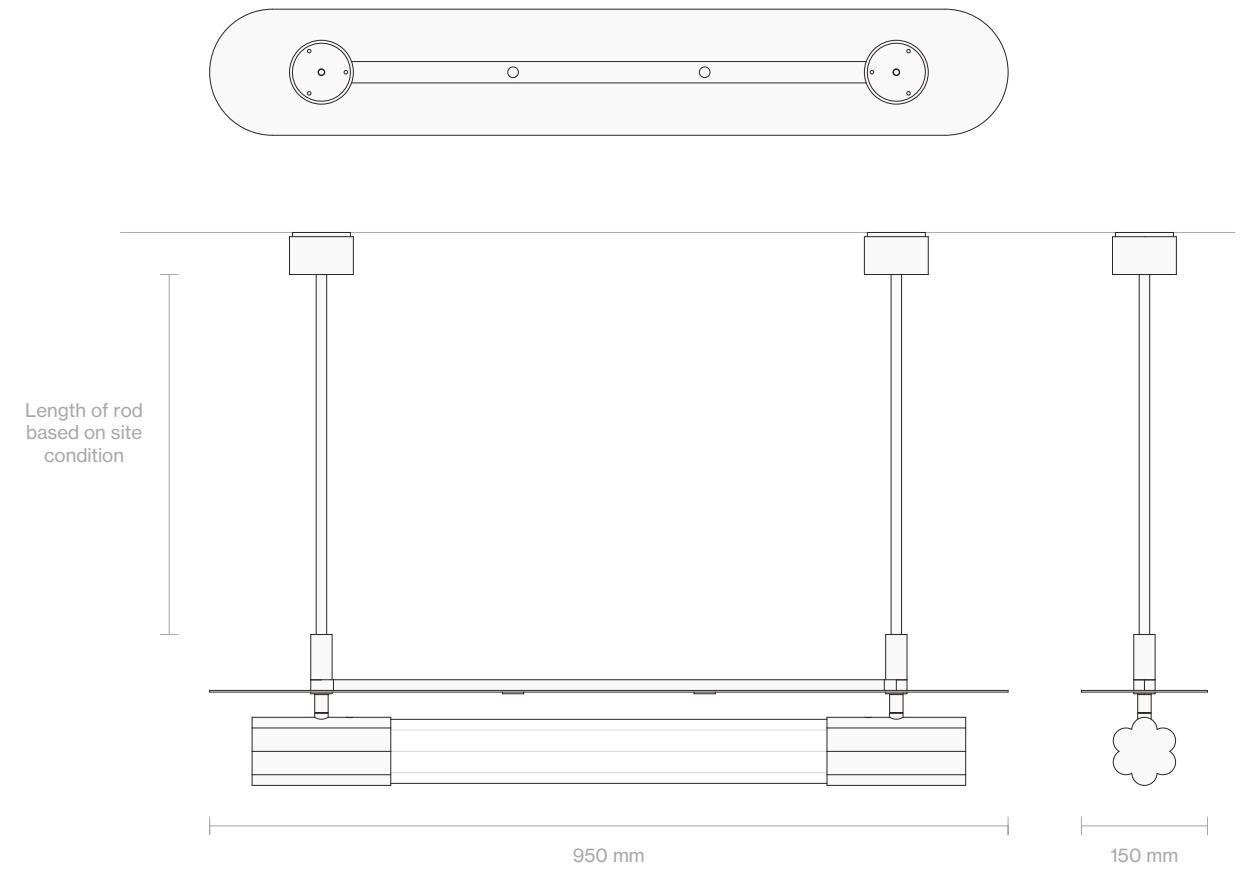
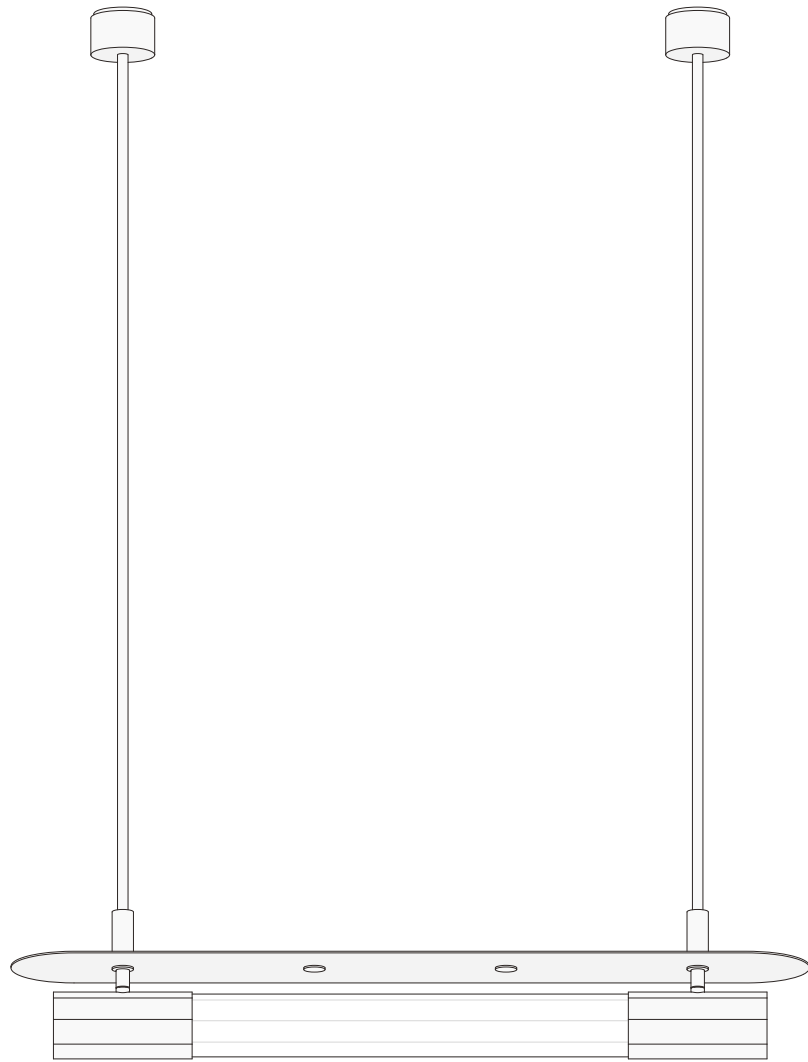

Horizontal Variant

Specifications

**Material
& Finish**

Body

Finish

Brass _____ Aged

Base for Floor Variant

White marble _____ Polished

Pink marble _____ Polished

Green marble _____ Polished

Black marble _____ Polished

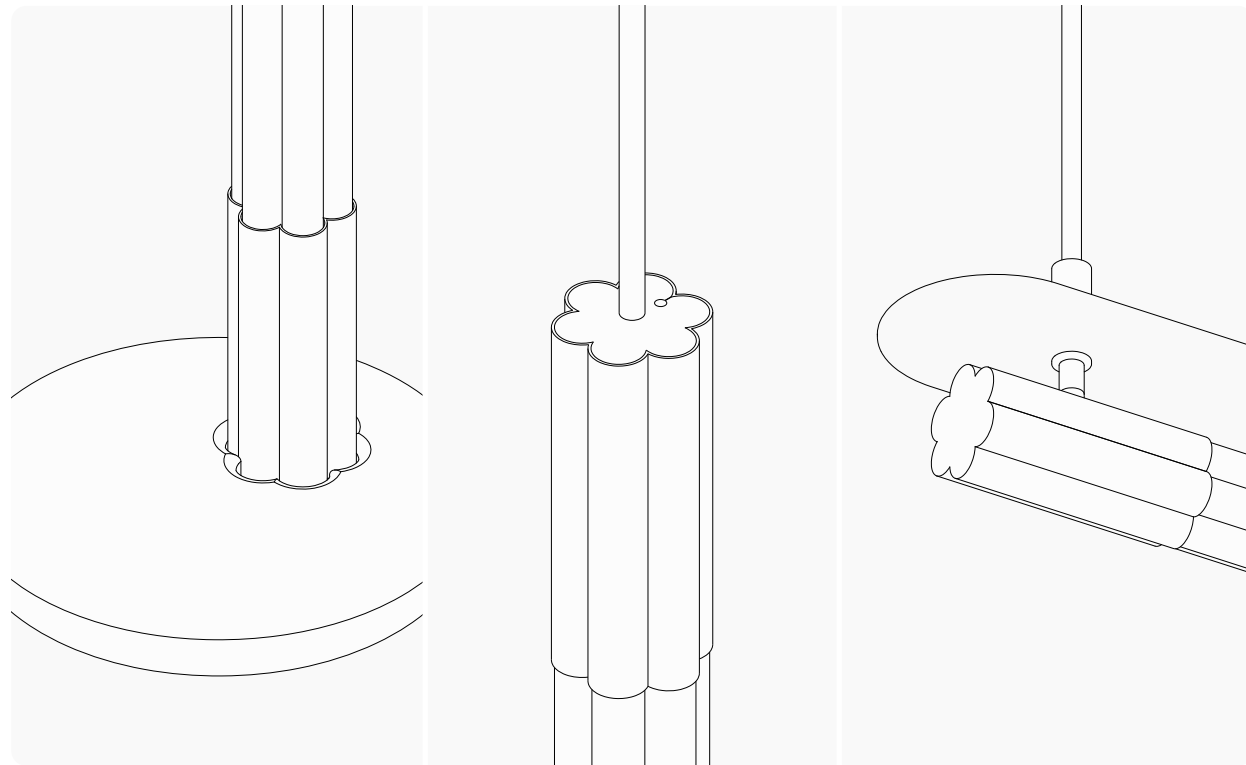

**Electrical
Specifications**

2 ft Light

Philips T8 Trulite Fluo Lamp -
warm white, 18W - 1350 lumens
- 220 / 240V

4 ft Light

Philips T8 Trulite Fluo Lamp -
warm white, 36W - 3250 lumens
- 220 / 240V

One Tube Light

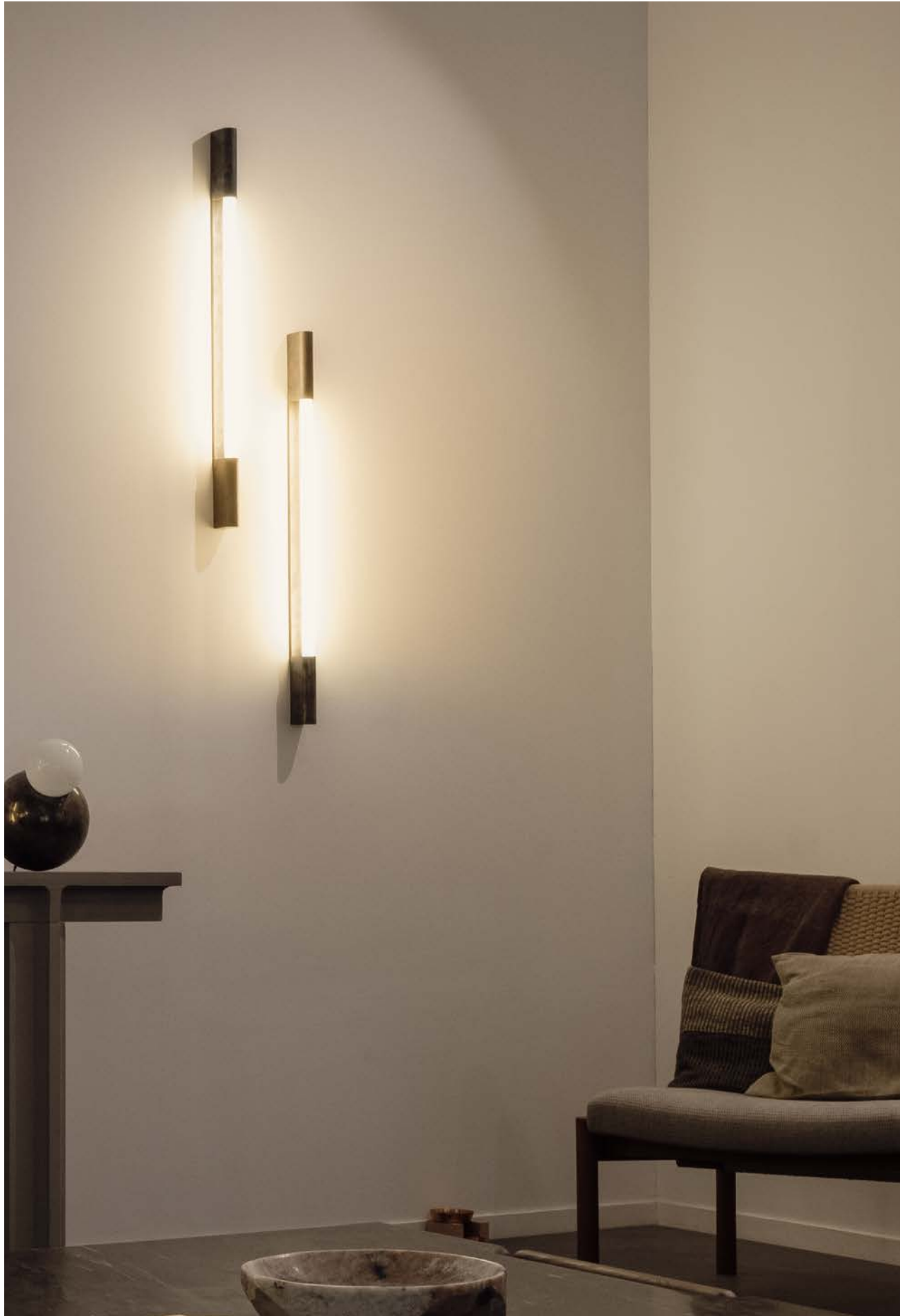

Specifications

**Material
& Finish**

Body

Finish

| | | |
|-------|-------|-----------|
| Brass | ————— | Aged |
| Brass | ————— | Blackened |

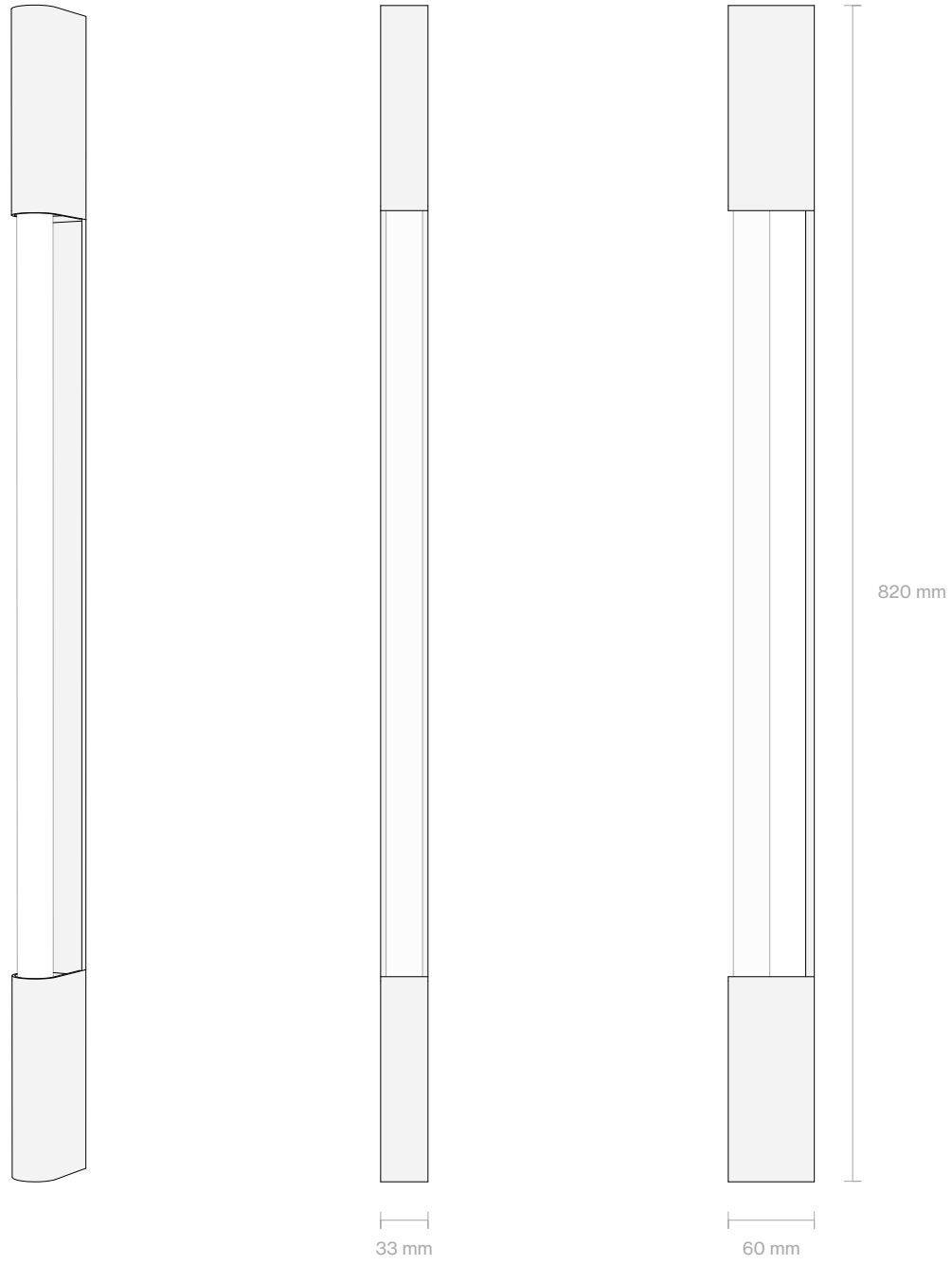

**Electrical
Specifications**

Philips T8 Trulite Fluor Lamp - warm white, 18W -
1350 lumens - 220 / 240V

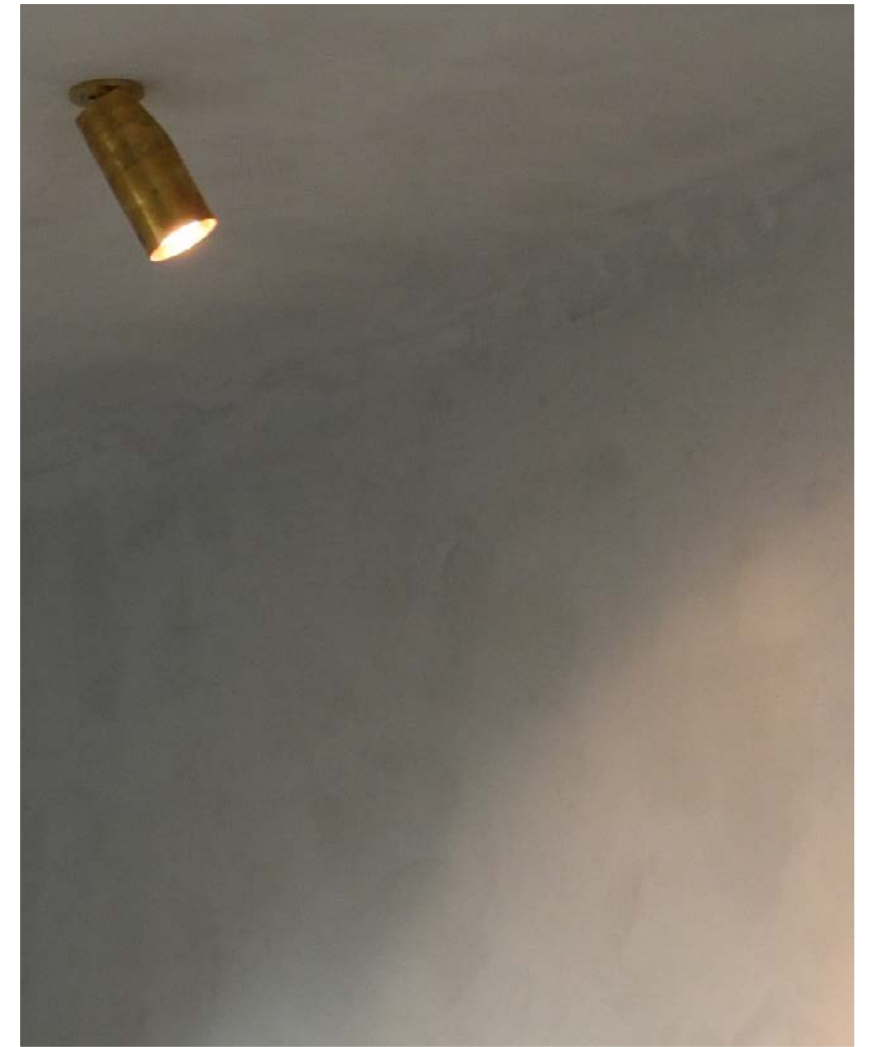

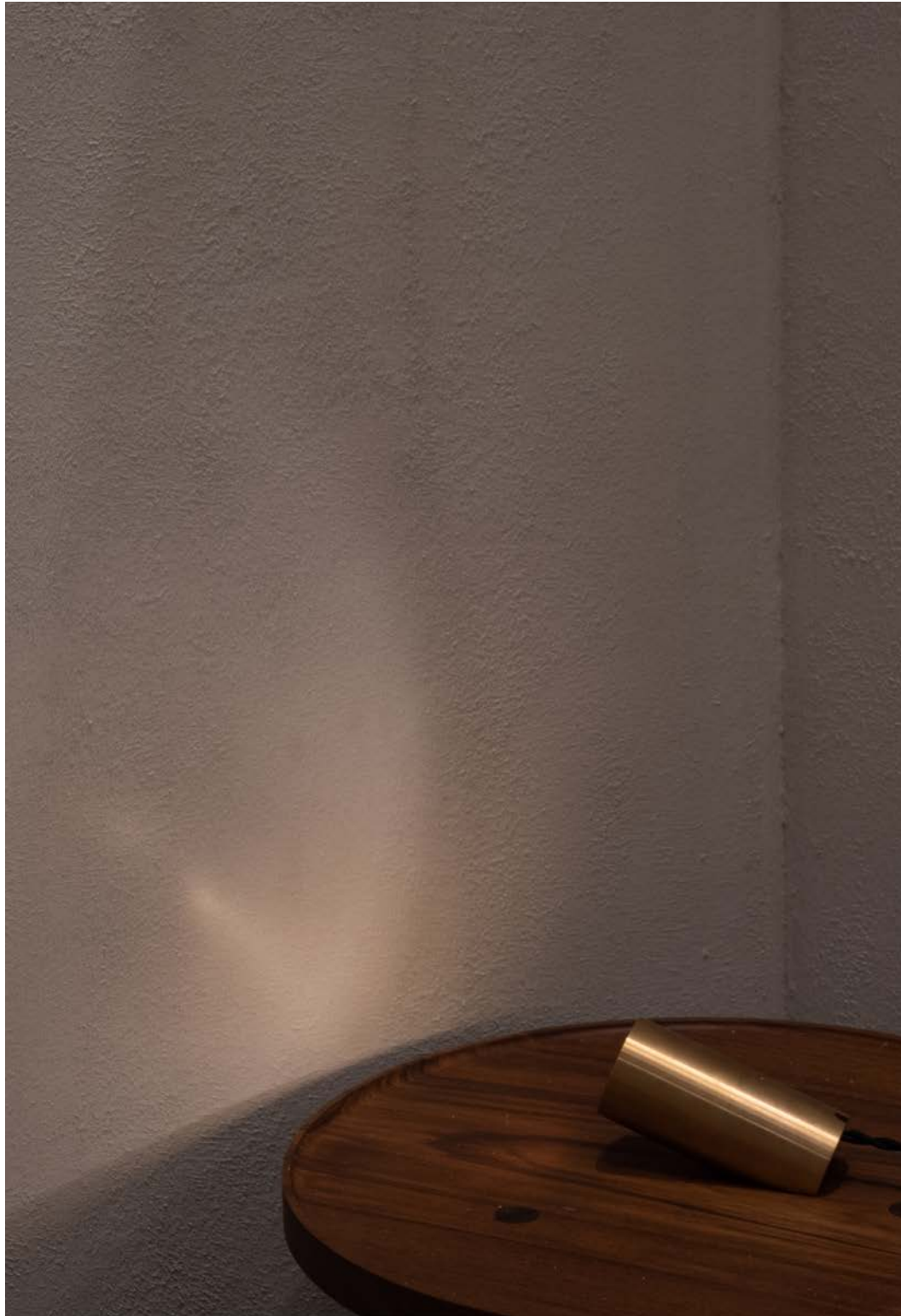



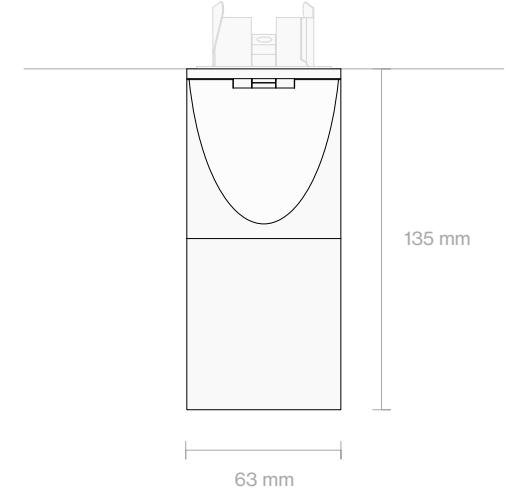
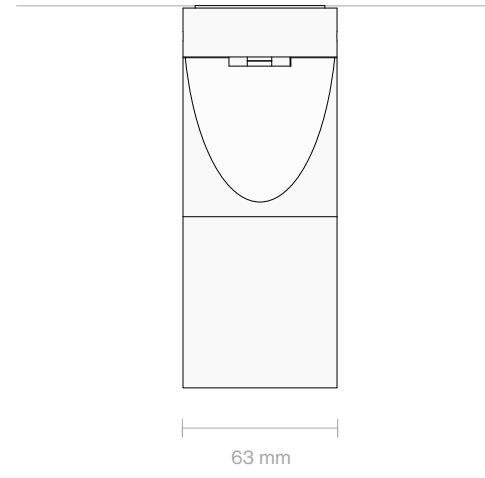
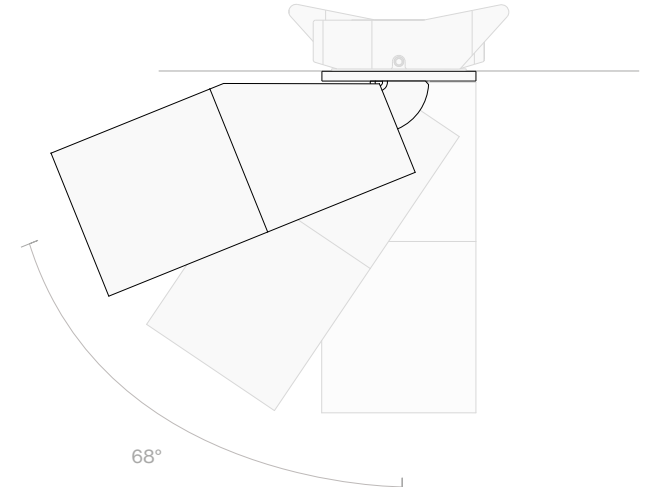
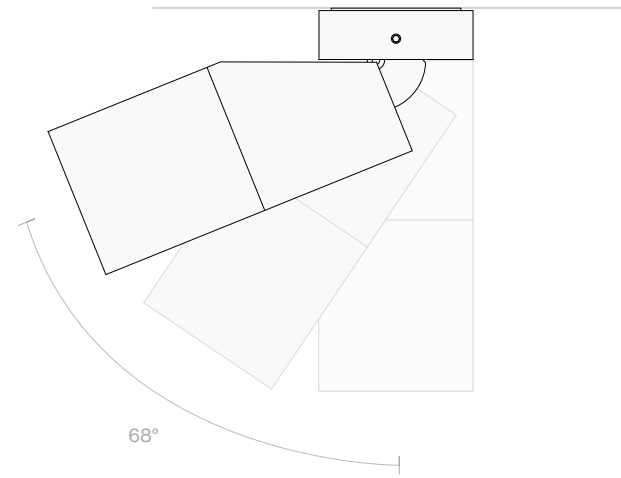
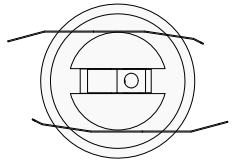
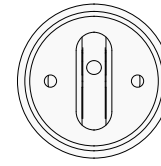
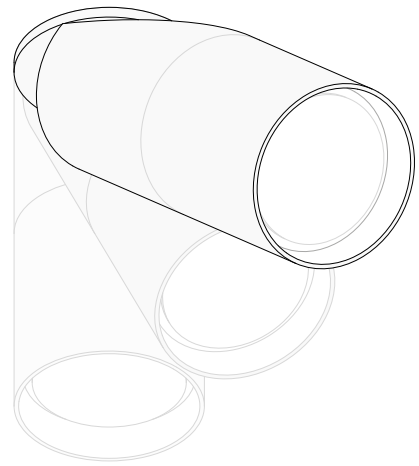
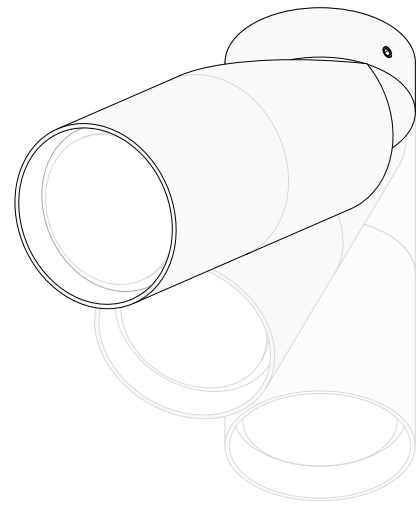

RCC Ceiling



Ceiling Variants



False Ceiling

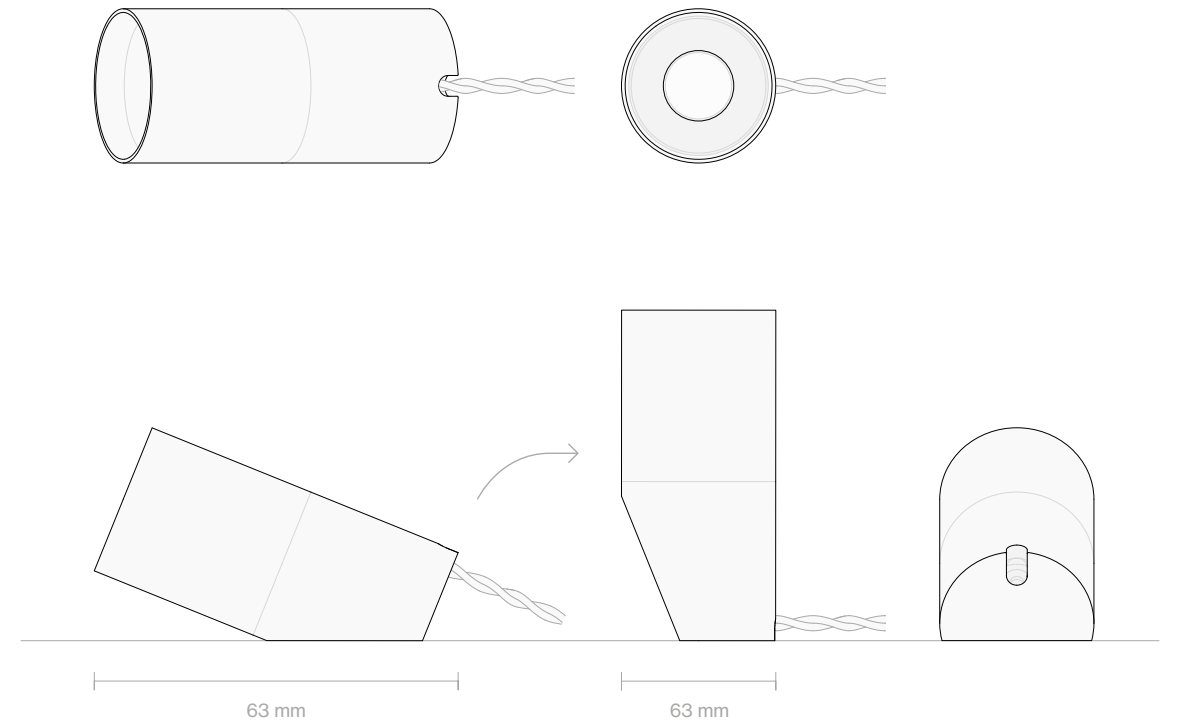
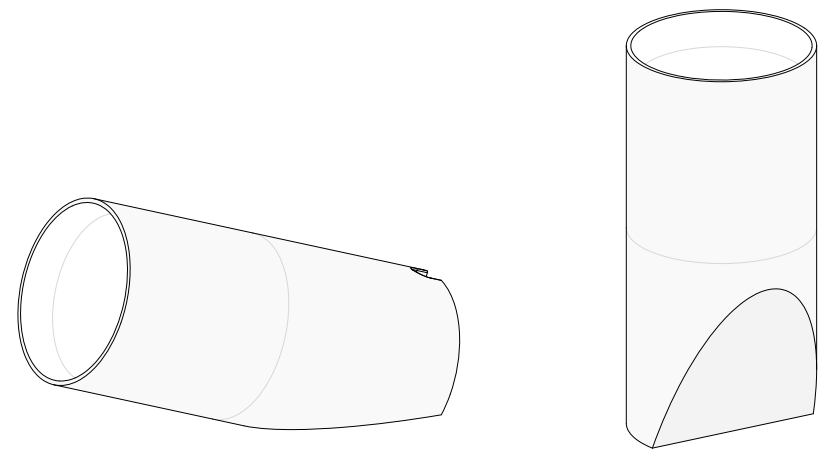
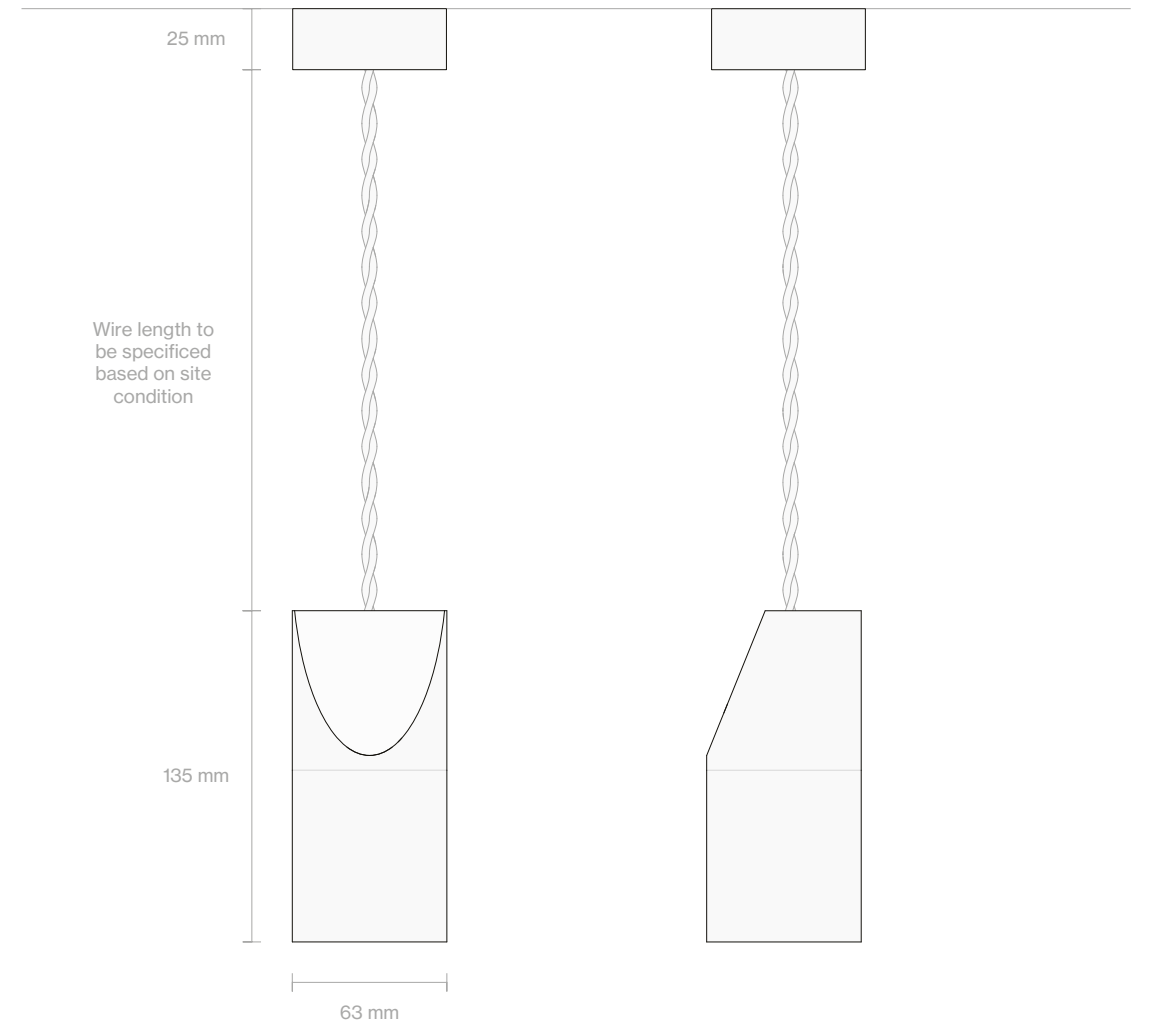
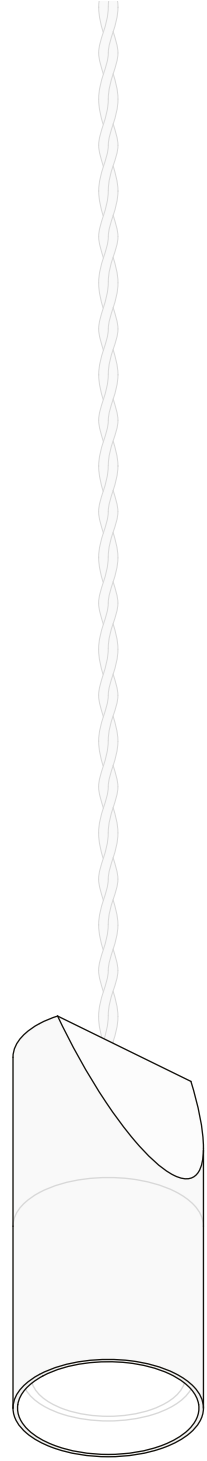
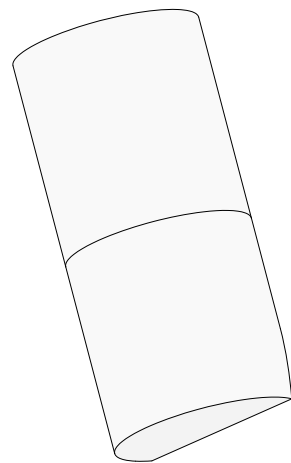
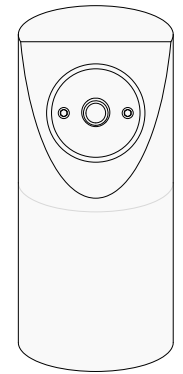
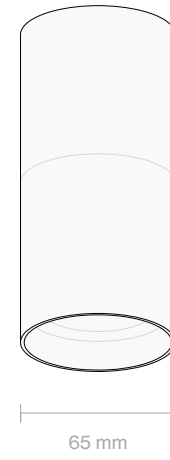
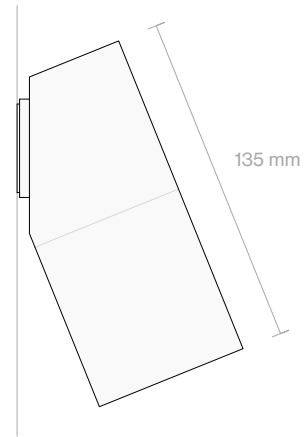
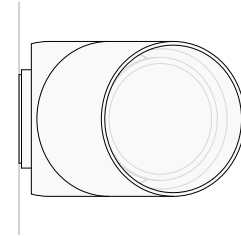
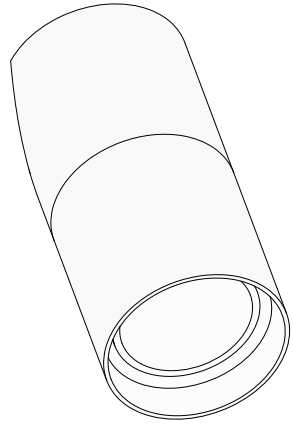

Table Variant



Pendant Variant



Wall Variant

Specifications

**Material
& Finish**

Body

Finish

Brass ———— Matte Polished / Aged / Blackened

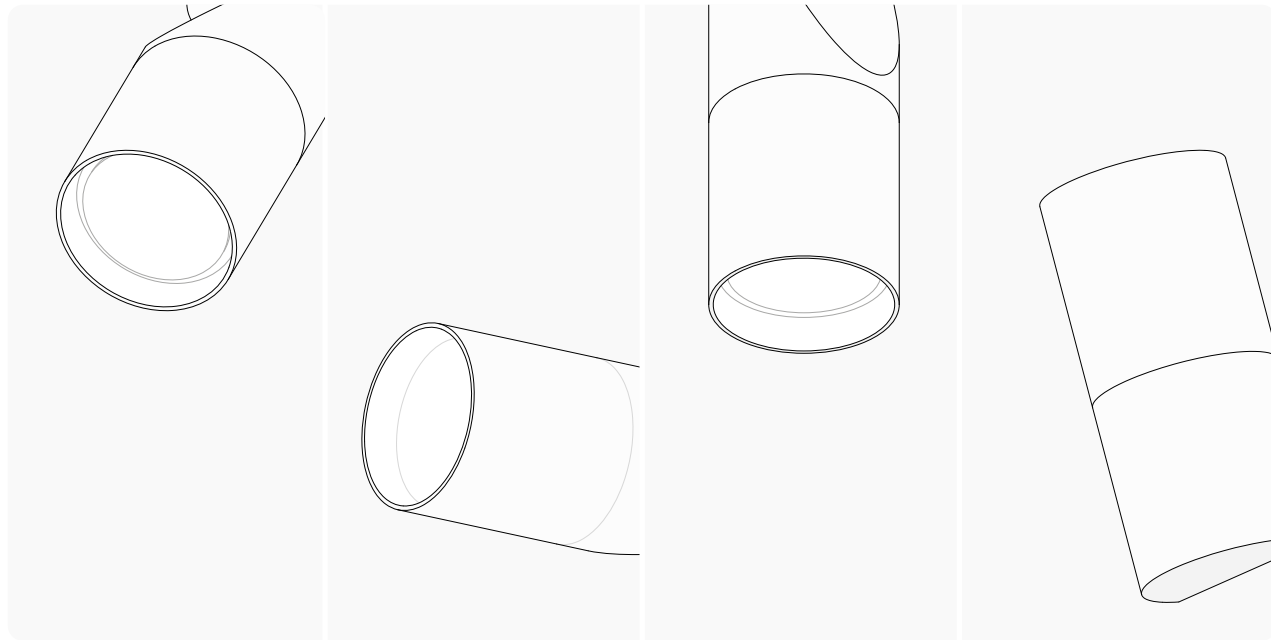



Standing Straight Lamp







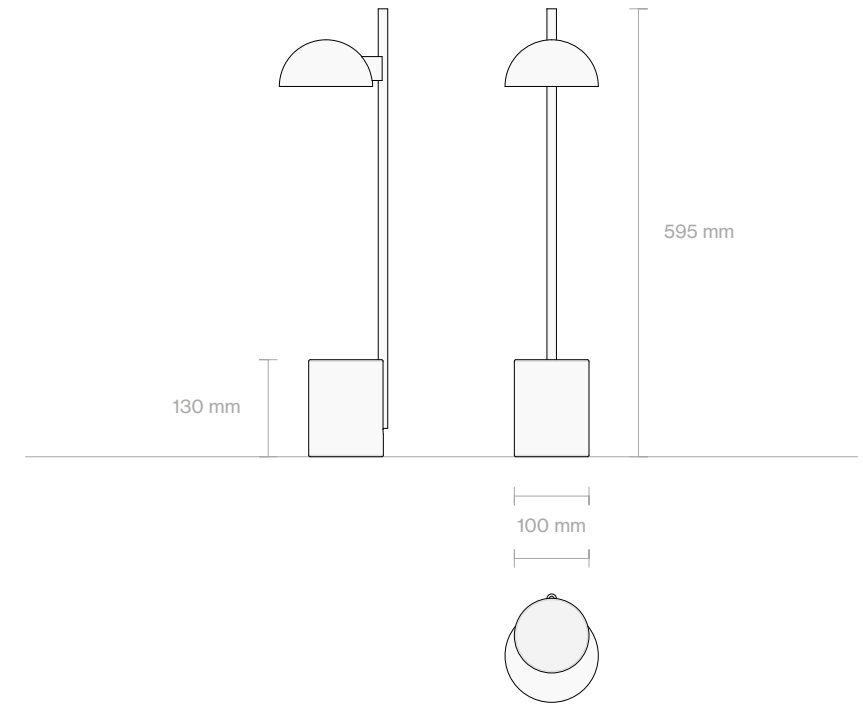
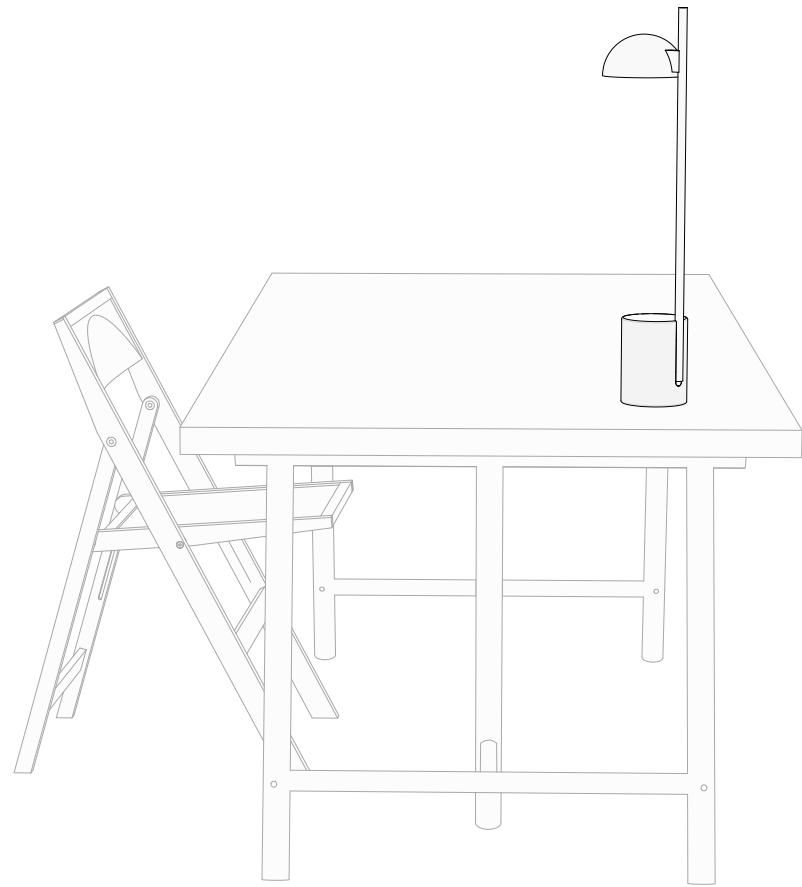
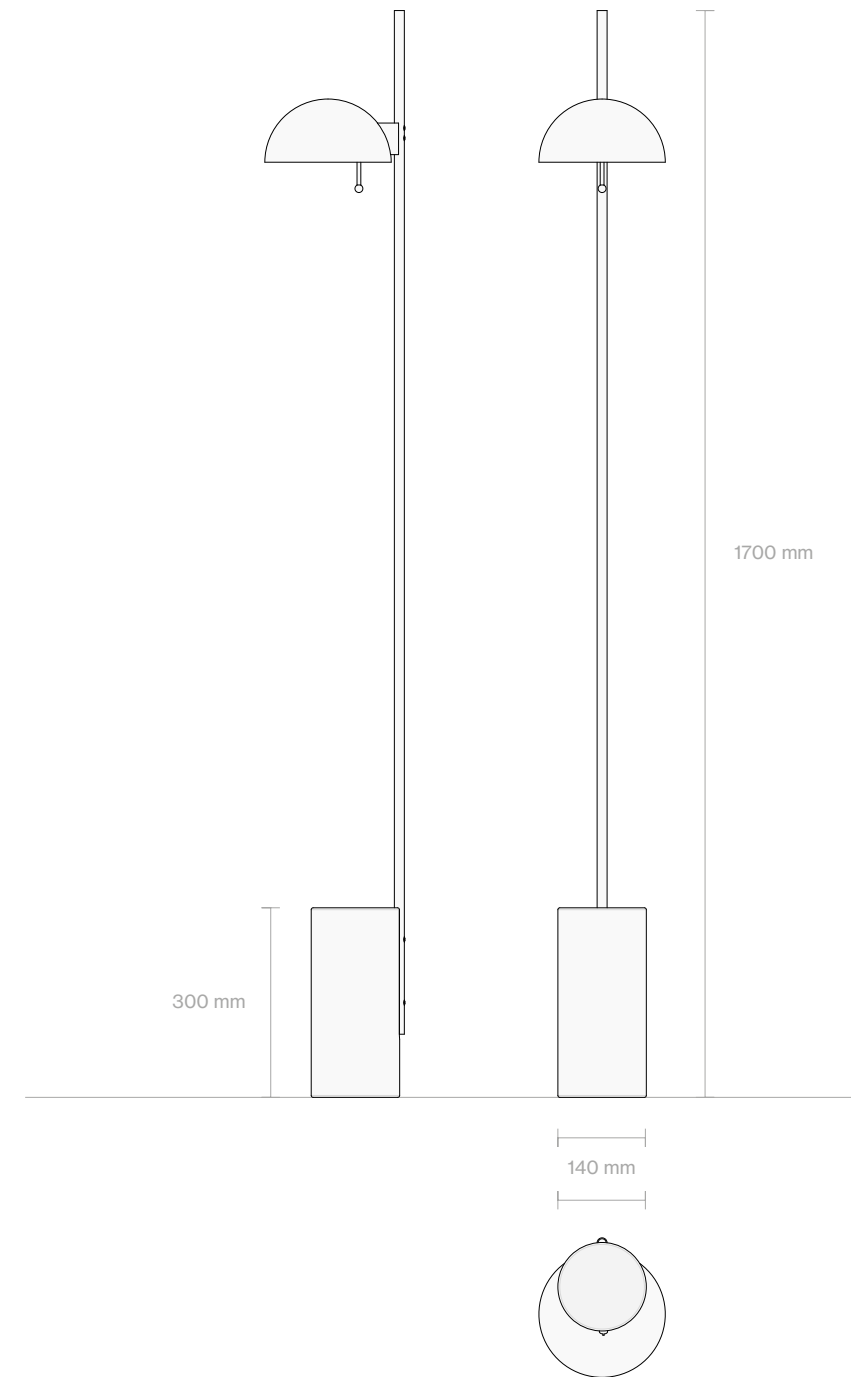
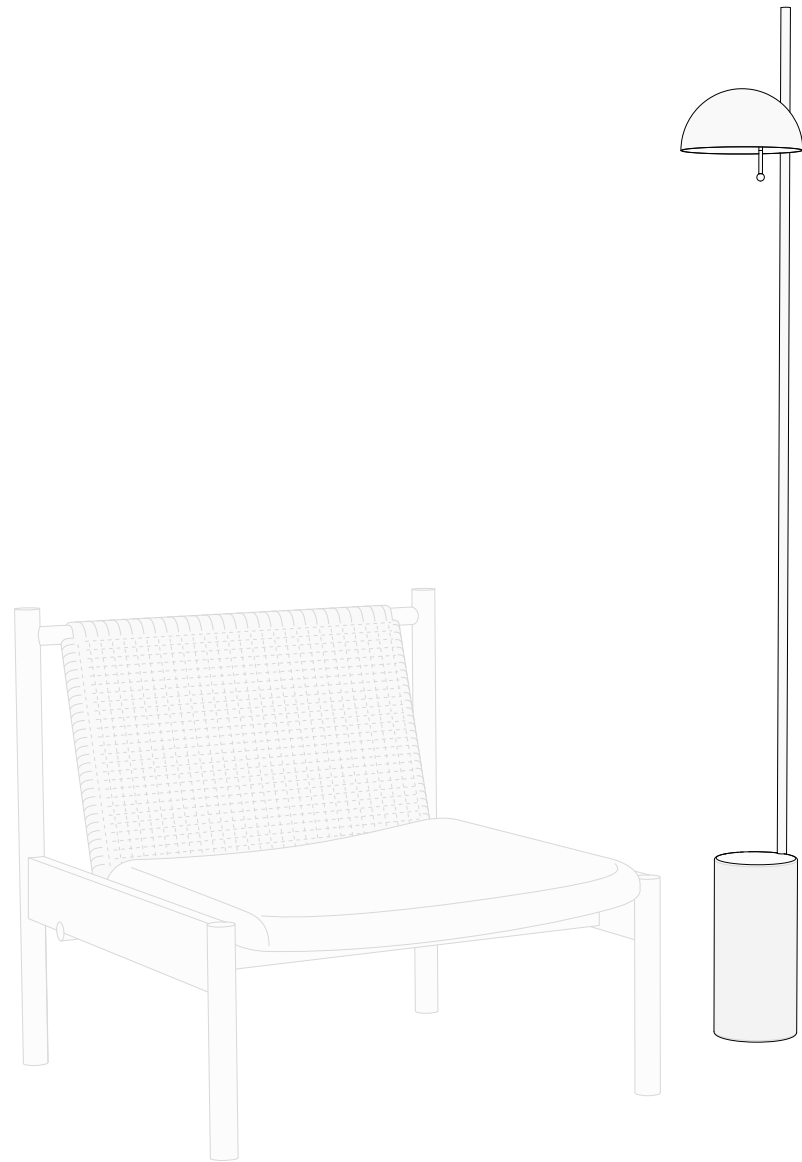

Table Variant



Floor Variant

Specifications

Material & Finish

Body

Finish

Brass ————— Matte Polished / Aged

Base

White Marble ————— Polished
 Pink Marble ————— Polished
 Black Marble ————— Polished
 Green Marble ————— Polished

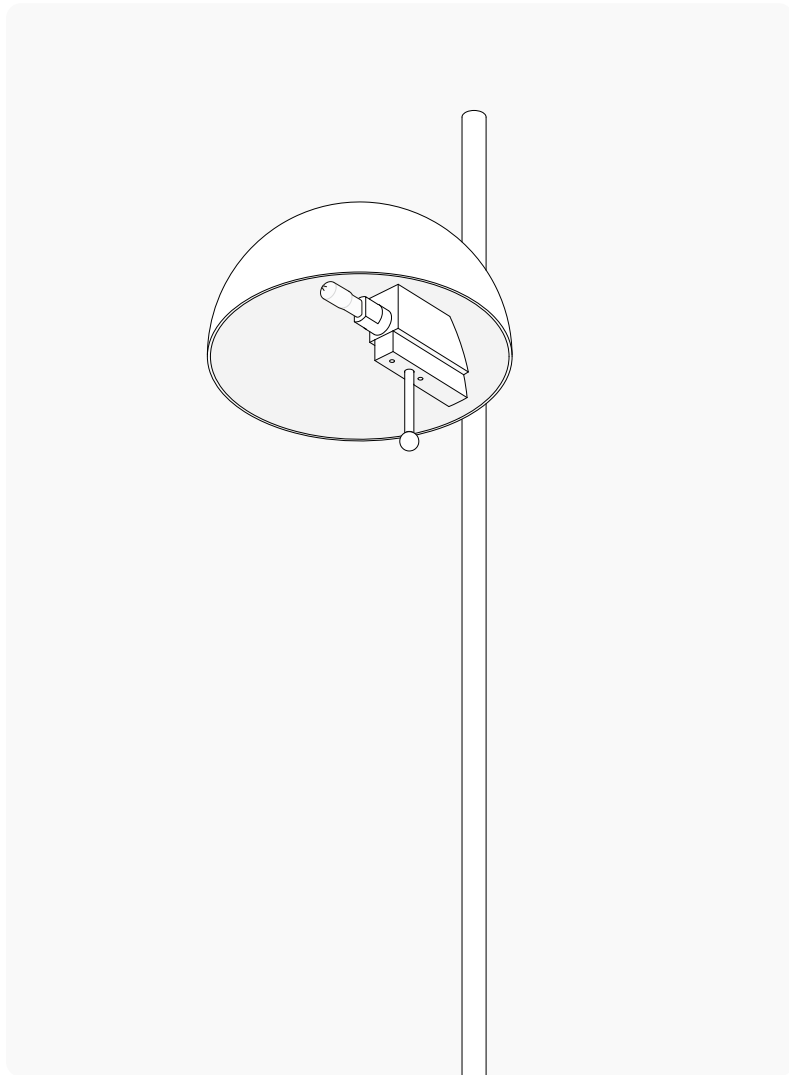

Electrical Specifications

Floor Lamp

Halogen Bulb G9 50W 240V, milky coat
 Dimmer Anchor pentamini dimmer 450W
 Plug Legrand 2P plug 16A, 220 - 240V
 Cord Snoerberg black cloth cord

Table Lamp

Halogen Bulb G9 50W 240V, milky coat
 Dimmer For 10-150W lightbulbs, incandescent & halogen bulbs (230V)
 Plug Legrand 2P plug 16A, 220 - 240V
 Cord Snoerberg black cloth cord



Buenos Diyas





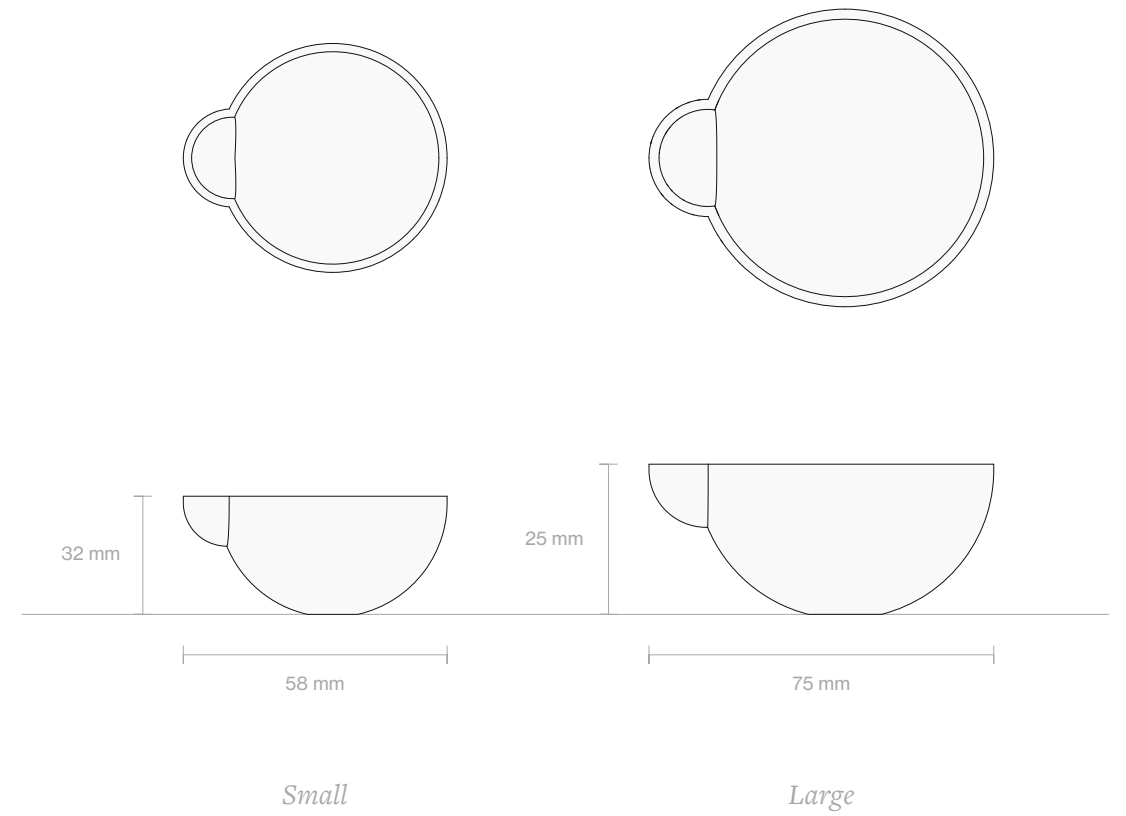
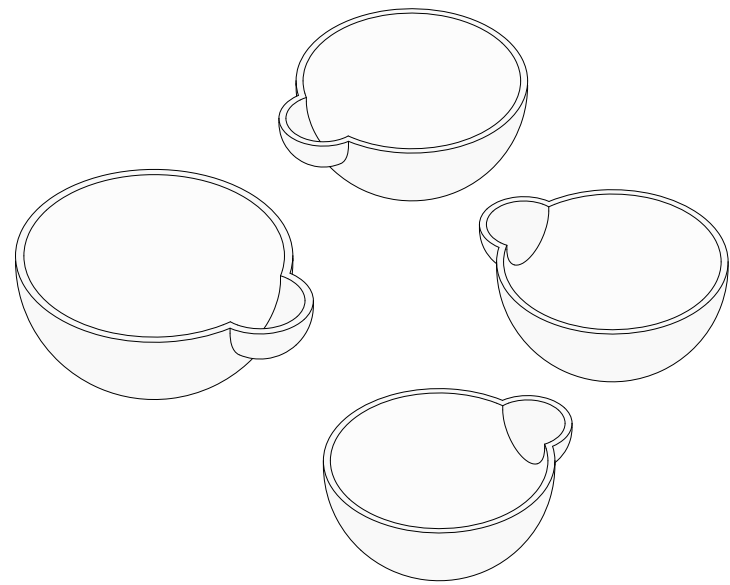

Specifications

**Material
& Finish**

Body

Finish

Brass

Cast

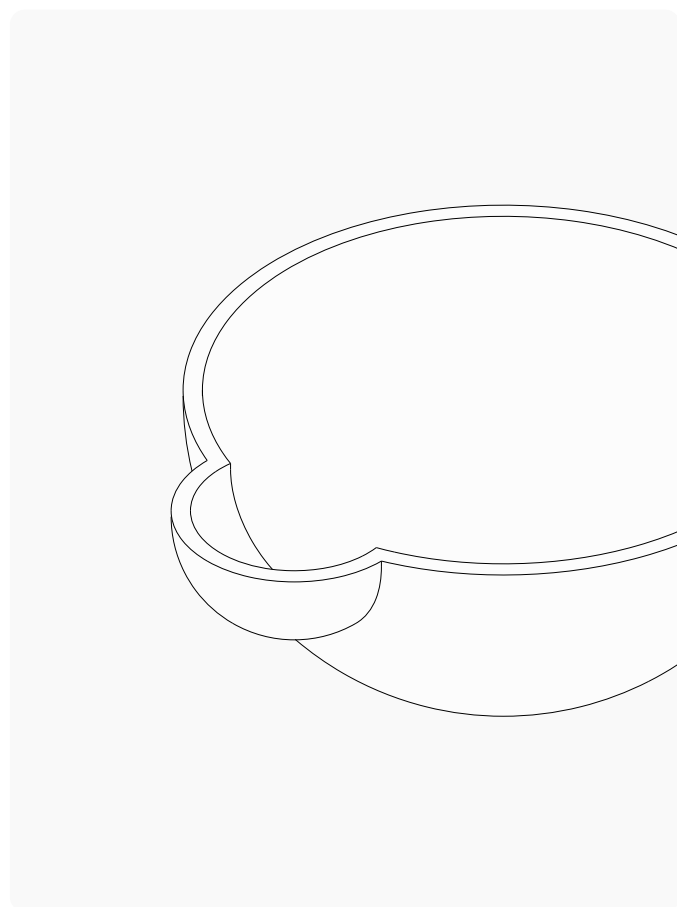



Building Blocks





Specifications

**Material
& Finish**

Body

Finish

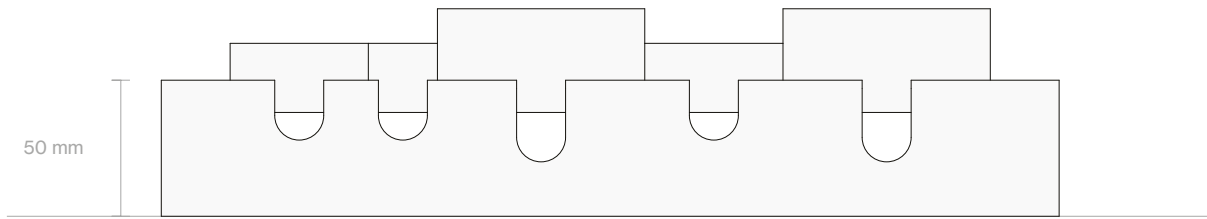
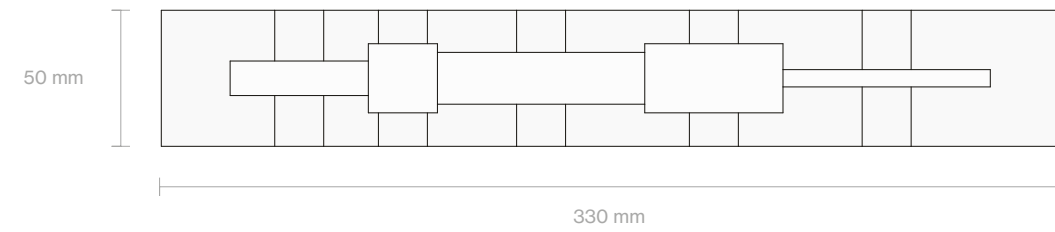

Mahogany

Oiled

Blocks

Brass

Aged

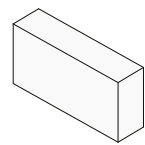

2 in x 1 in x 1/2 in

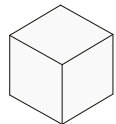

1 in x 1 in x 1 in

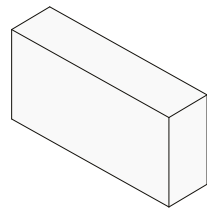

3 in x 1 1/2 in x 1/4 in

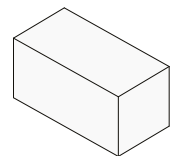

2 in x 1 in x 1 in

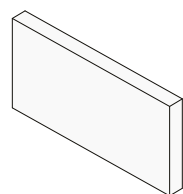

3 in x 1/4 in x 1 1/2 in

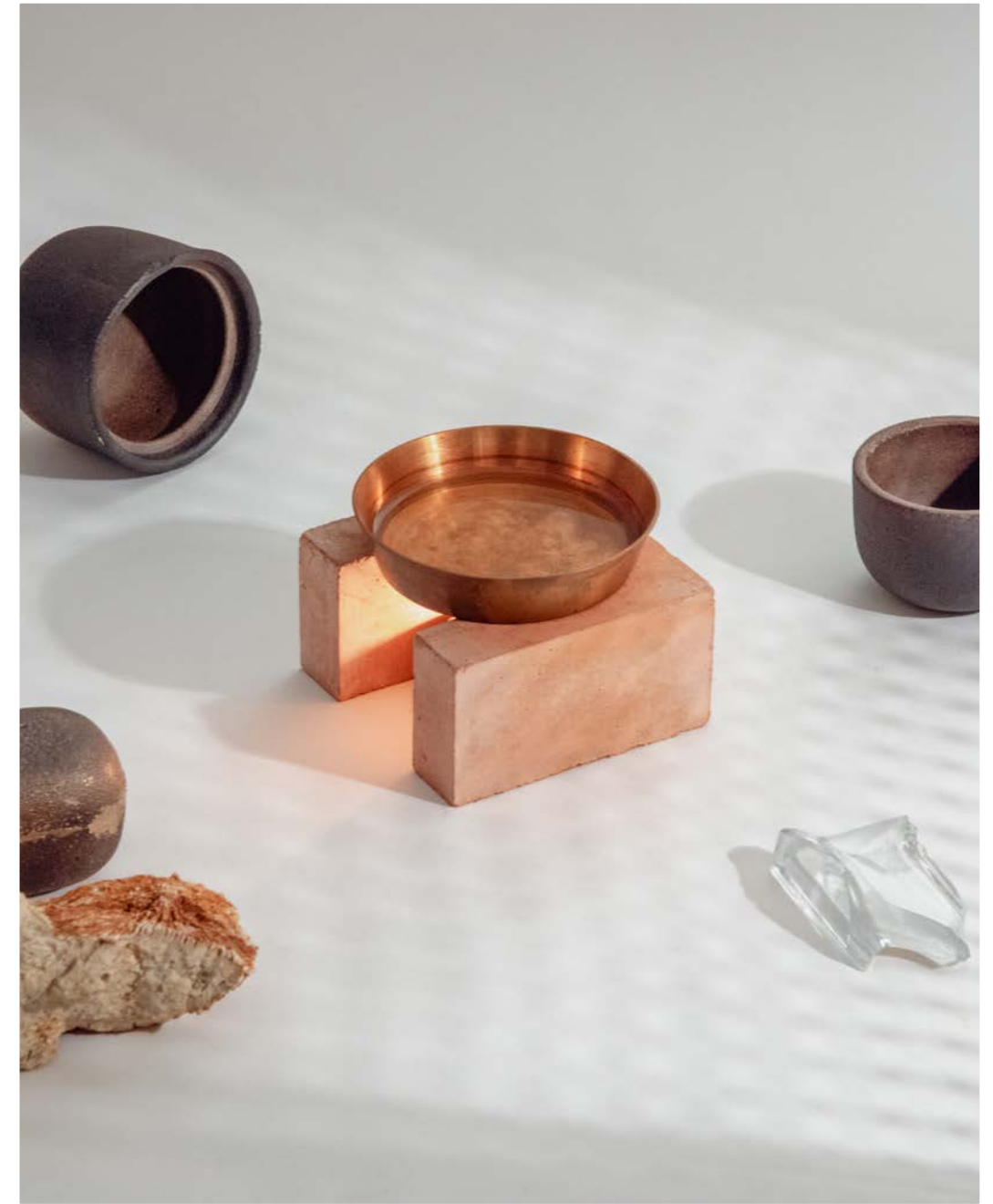
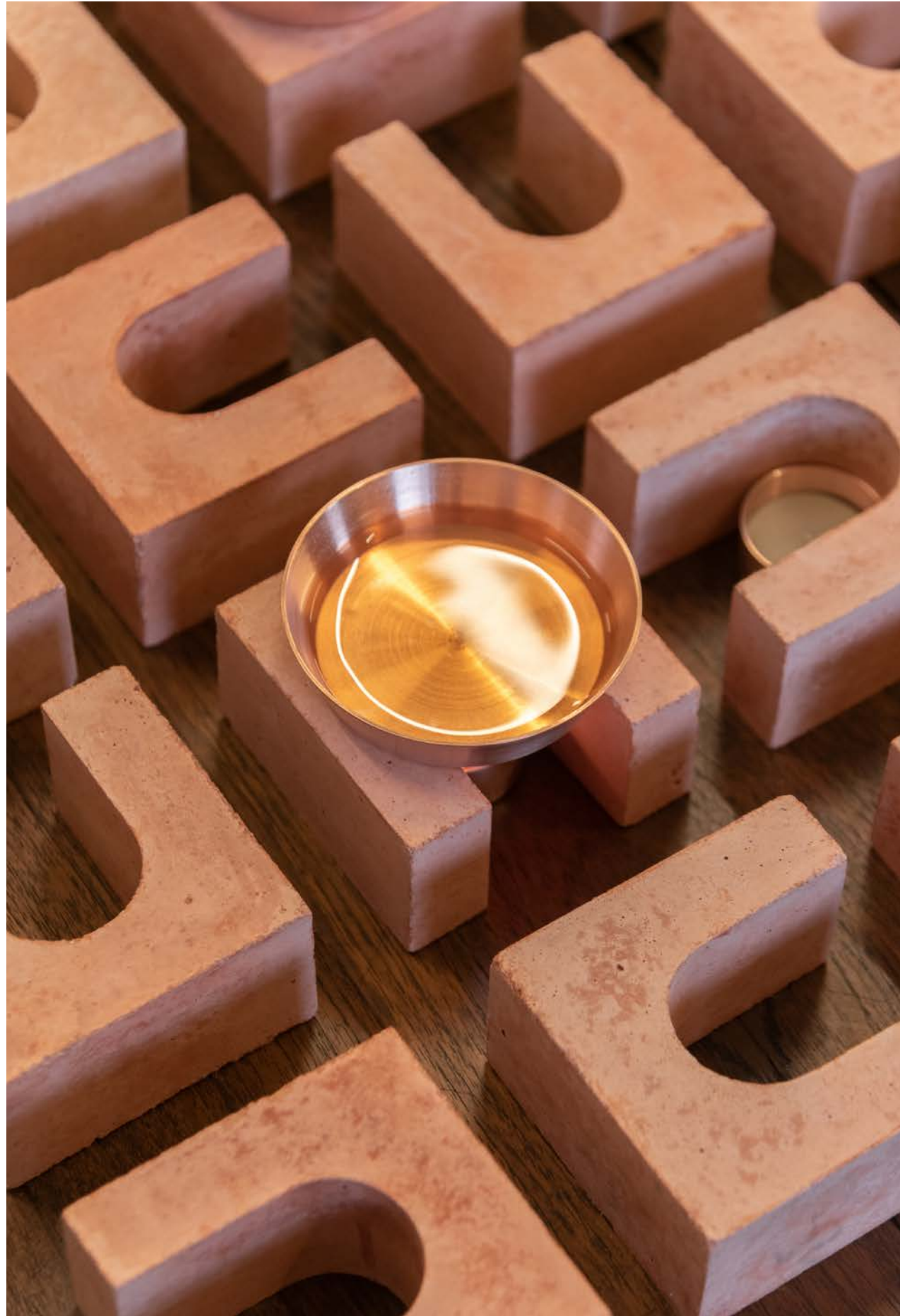



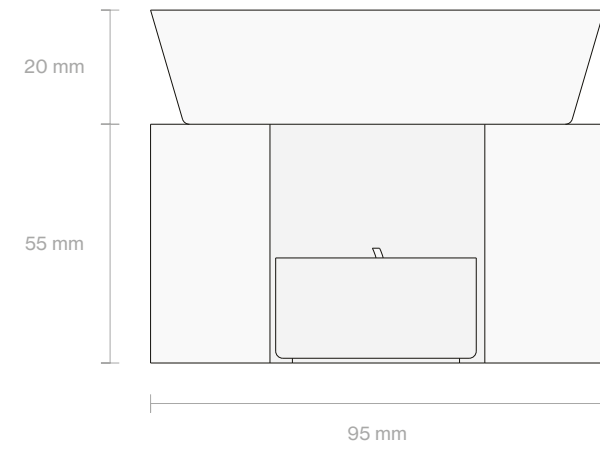
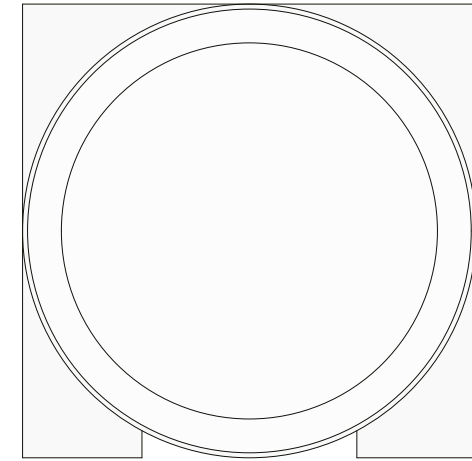
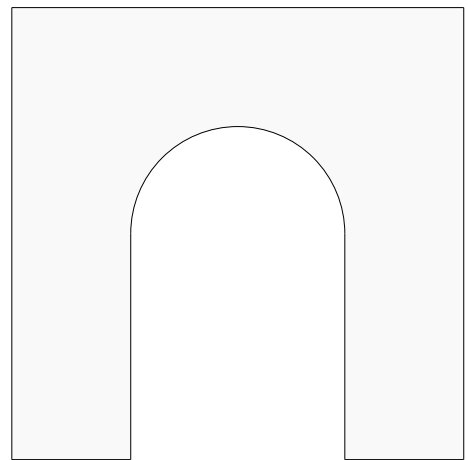
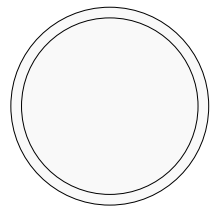
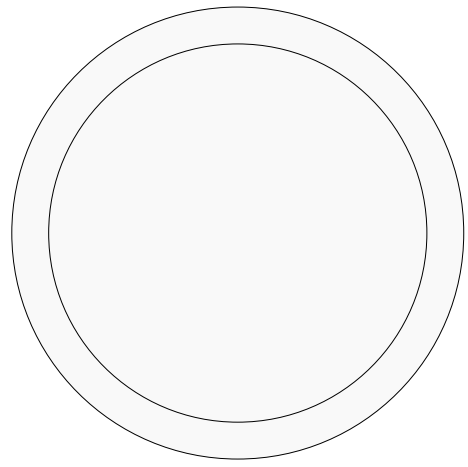

Specifications

**Material
& Finish**

Block

Finish

Cast Lime ————— Waxed

Basin

Copper ————— Polished

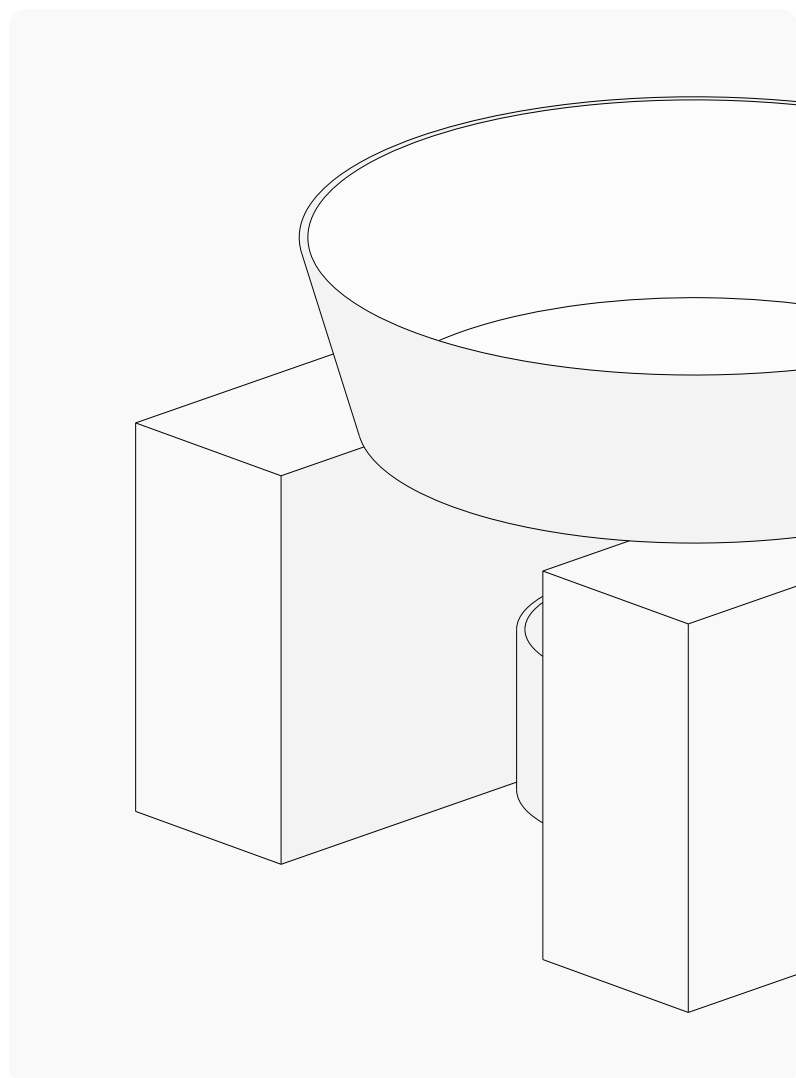





Specifications

Material
& Finish

Body

Finish

Brass

Polished

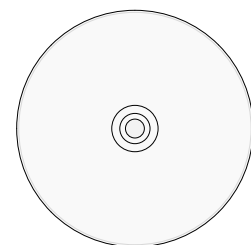
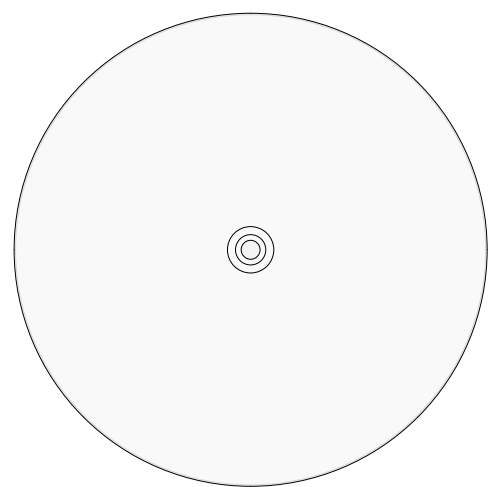
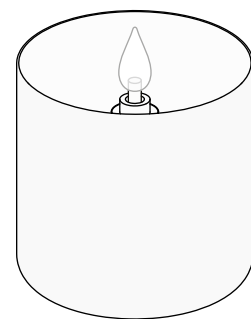
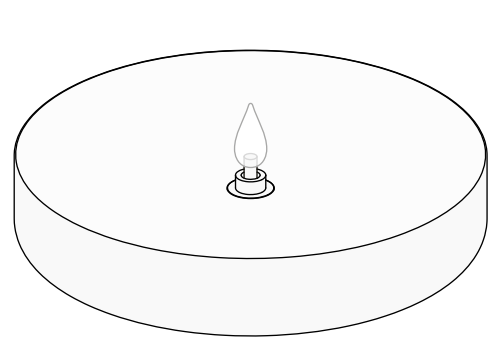

50 mm

50 mm

Ø 100 mm

Ø 50 mm

Wide

Tall

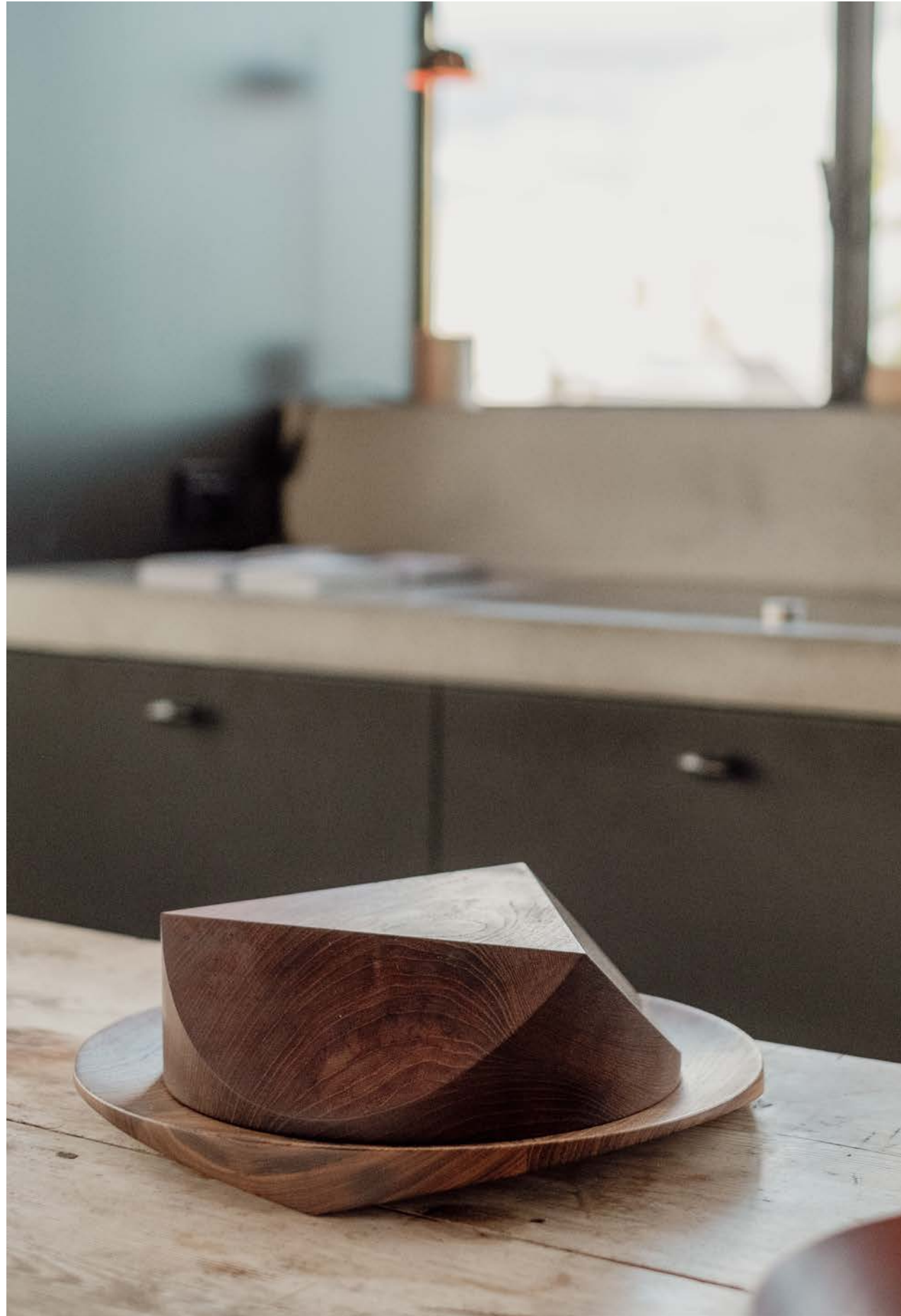

Topologic Bowls

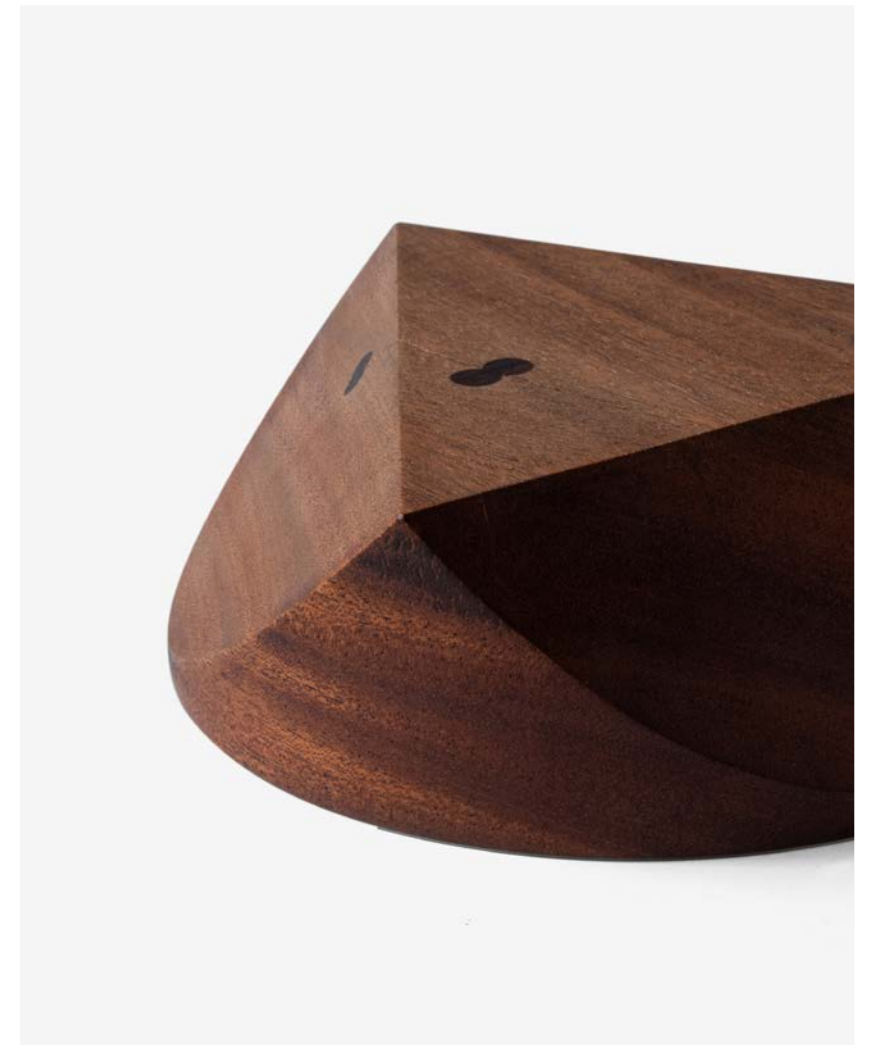



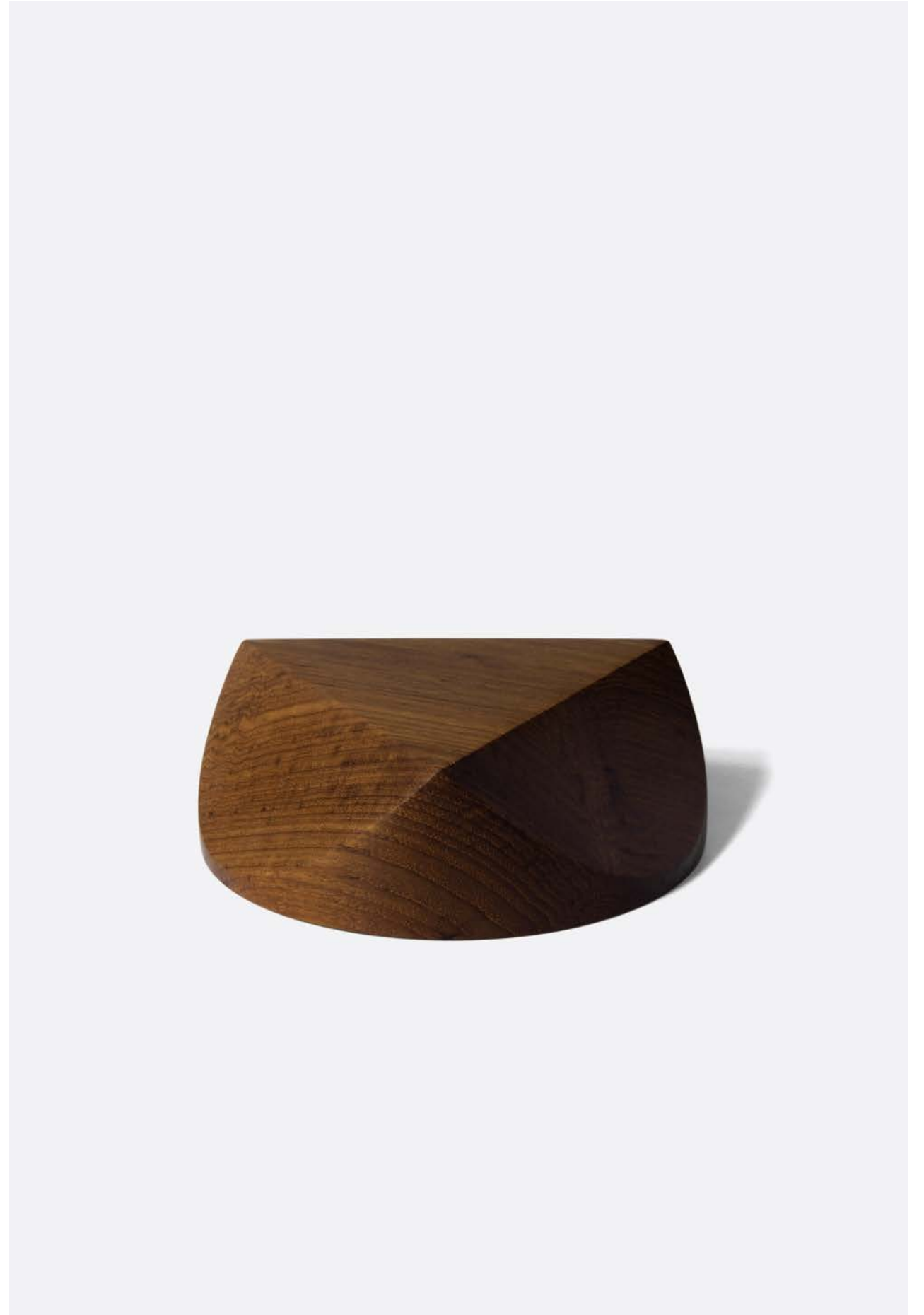

Specifications

**Material
& Finish**

Body

Finish

| | | |
|----------|-------|------------|
| Mahogany | ————— | Edible Oil |
| Teak | ————— | Edible Oil |

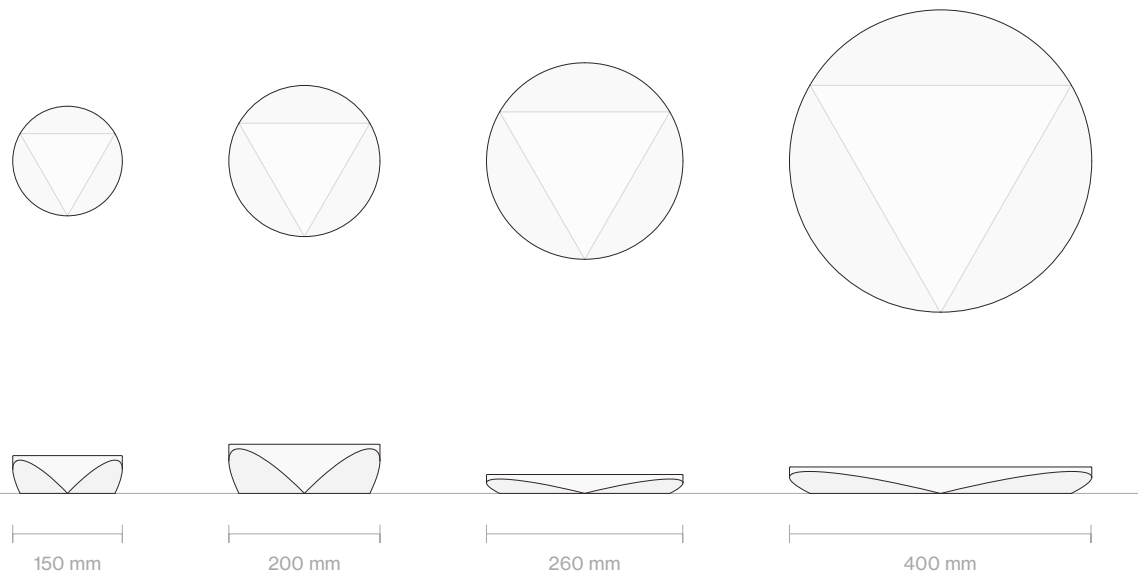
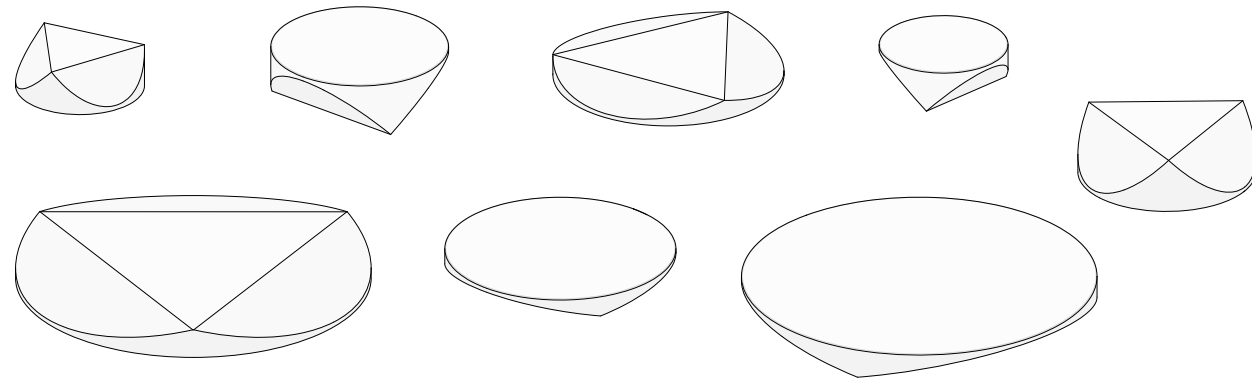



Fold Dhurries

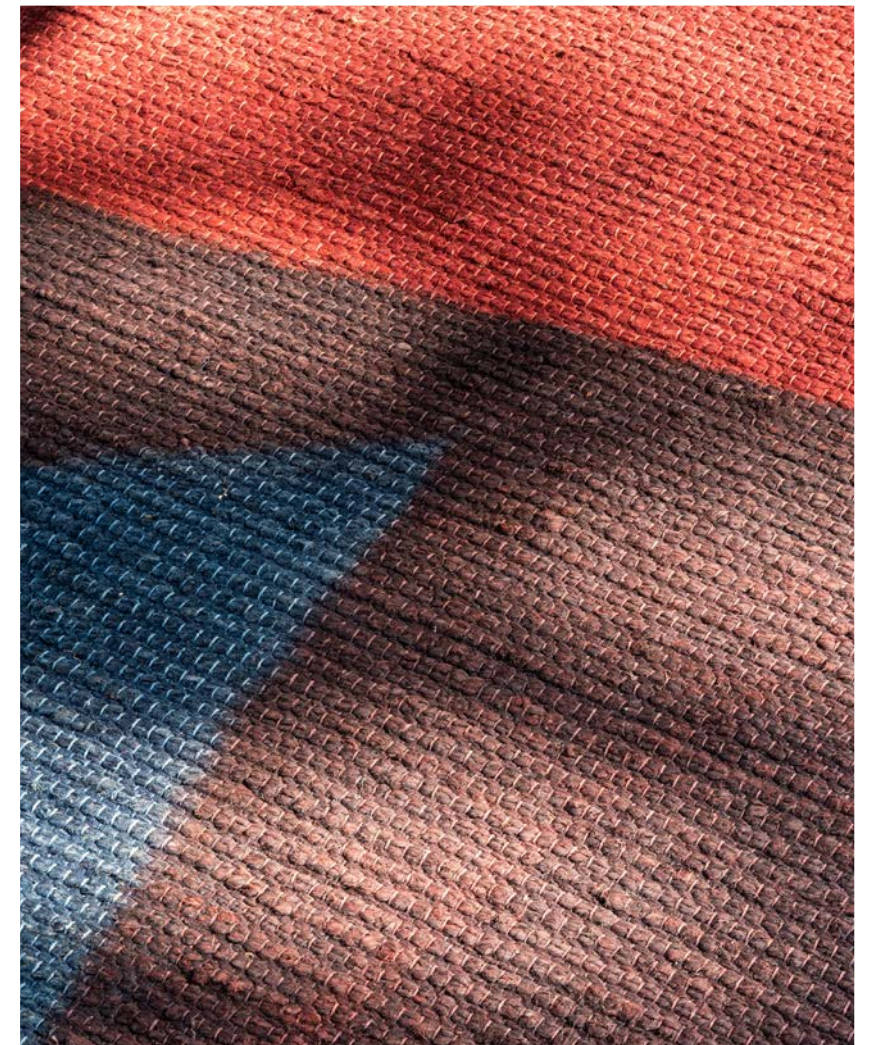

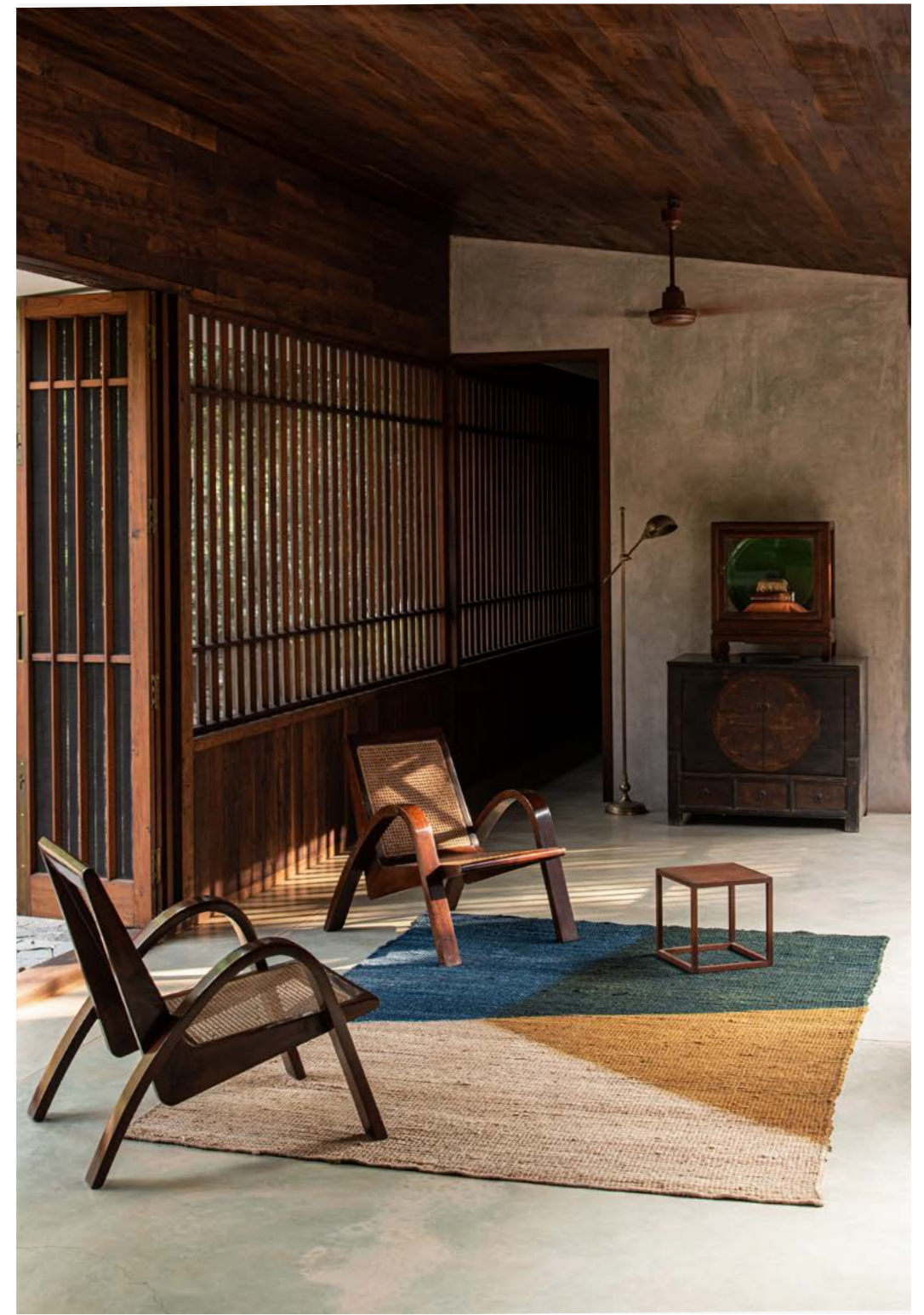

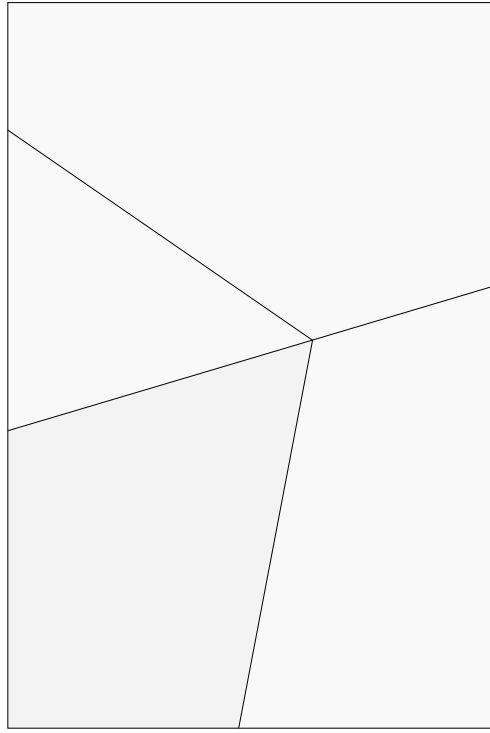

Delta

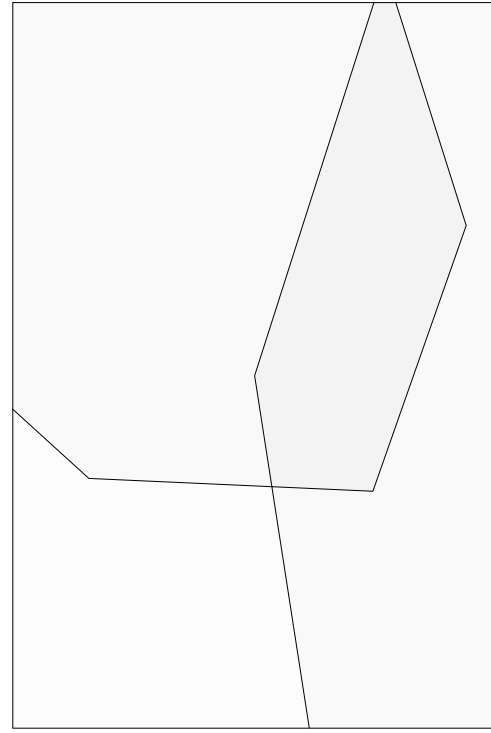

Umbra

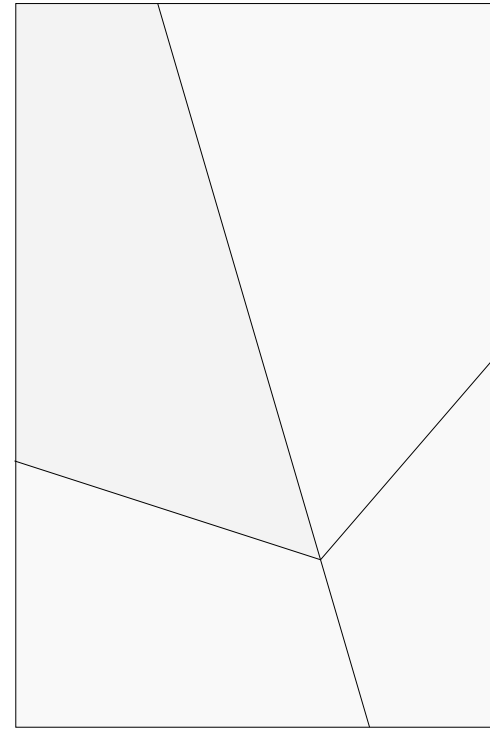

Aero

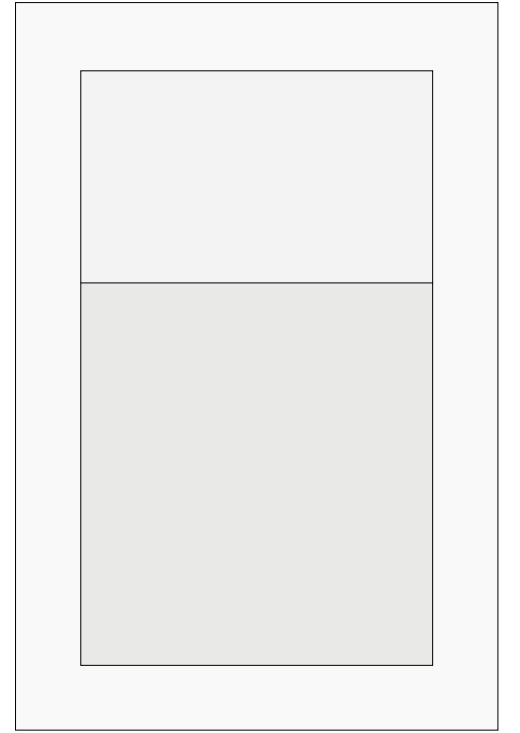

Dawn

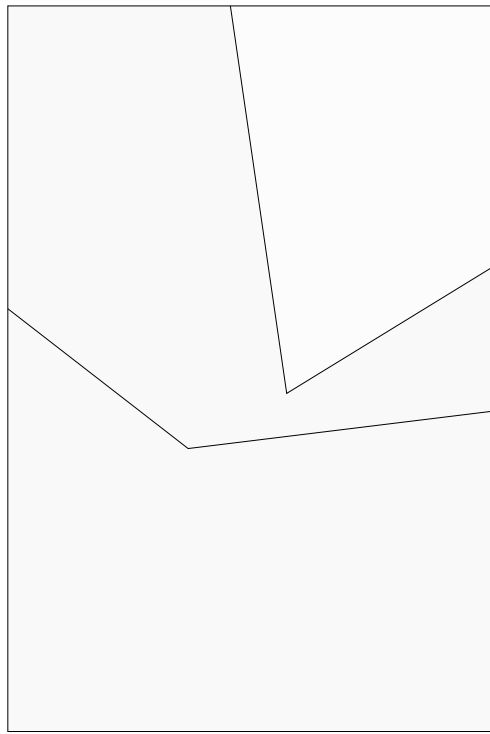

Valley

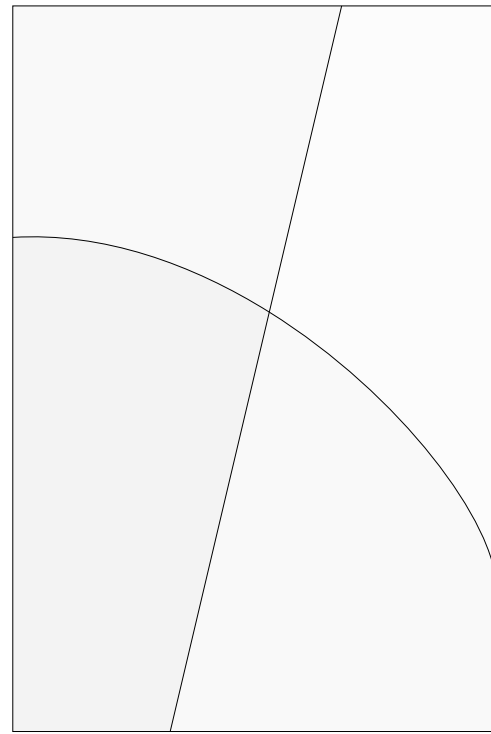

Curve

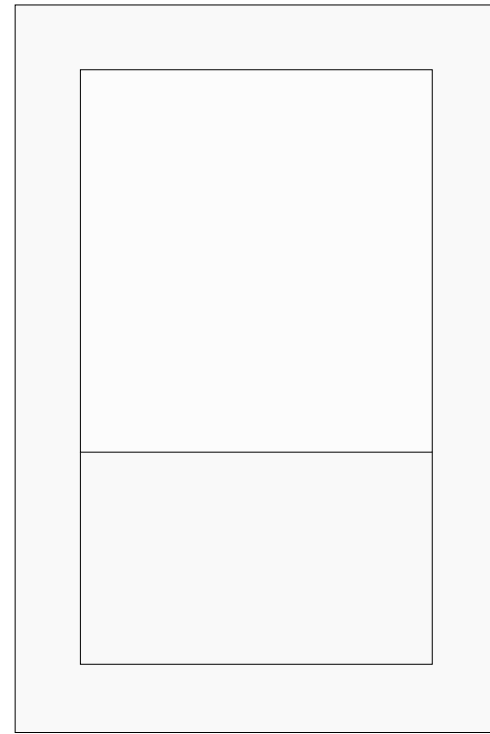

Dusk

Specifications

**Material
& Finish**

Fabric

Finish

Jute ————— Naturally Dyed

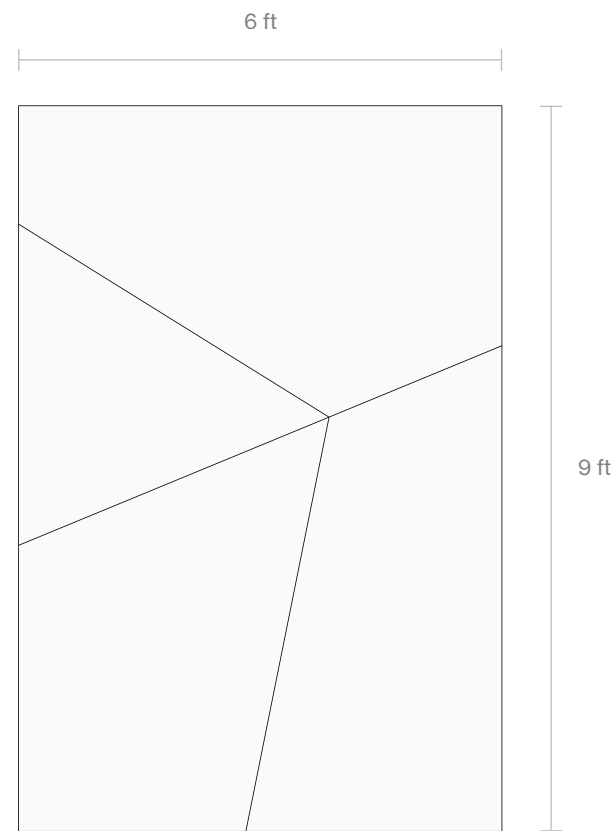
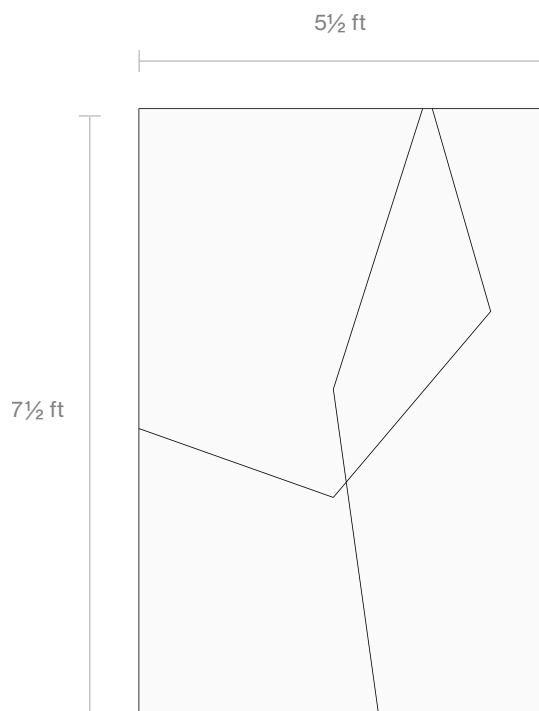
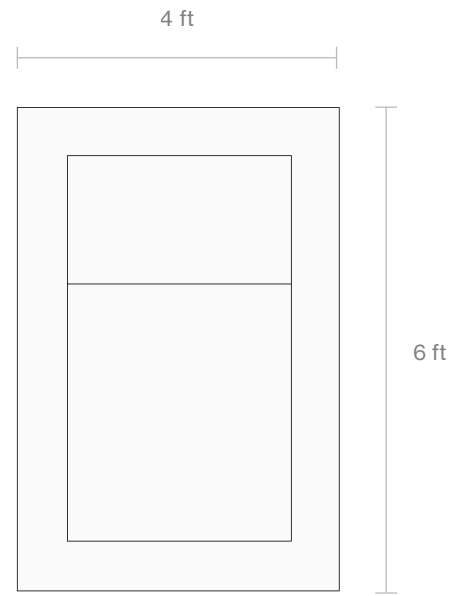
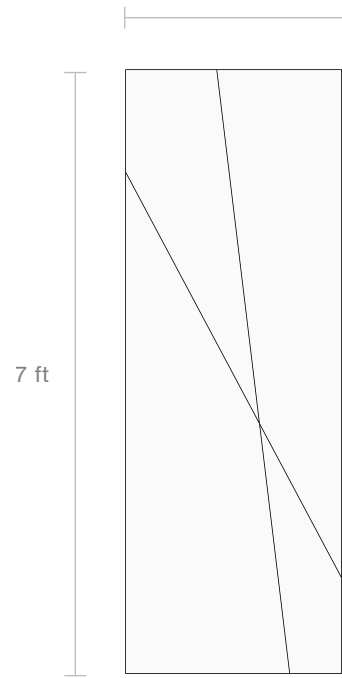



Specifications

**Material
& Finish**

Fabric

Finish

Brass ————— Matte / Aged / Blackened
Aluminium ————— Matte / Anodised

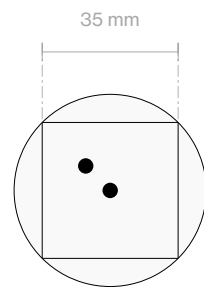
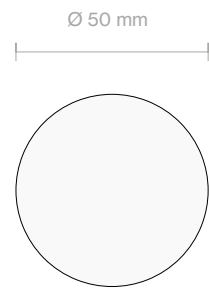
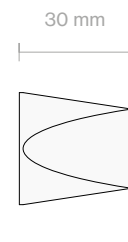
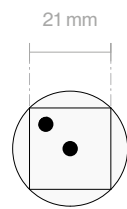
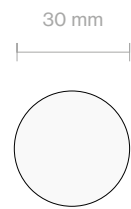

Front

Back

Side



Cylinder Collection of Handles







Specifications

**Material
& Finish**

Fabric

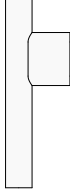
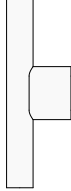
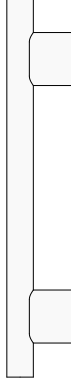
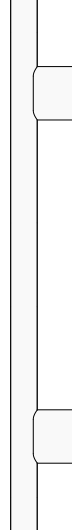
Finish

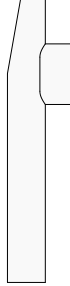
Brass ————— Matte / Aged / Blackened

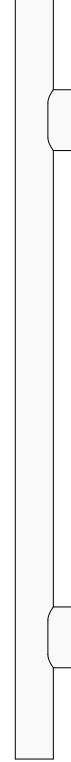
| Type 1 | Type 2 | Type 3 | Type 4 | Type 5 | Type 6 | Type 7 | Type 8 |
|--|---|--|--|--|---|--|--|
| Ø 14 mm H 100 mm | Ø 14 mm H 100 mm | Ø 14 mm H 200 mm | Ø 14 mm H 280 mm | Ø 14 mm H 360 mm | Ø 20 mm H 150 mm | Ø 20 mm H 300 mm | Ø 20 mm H 400 mm |
|  |  |  |  |  |  |  |  |

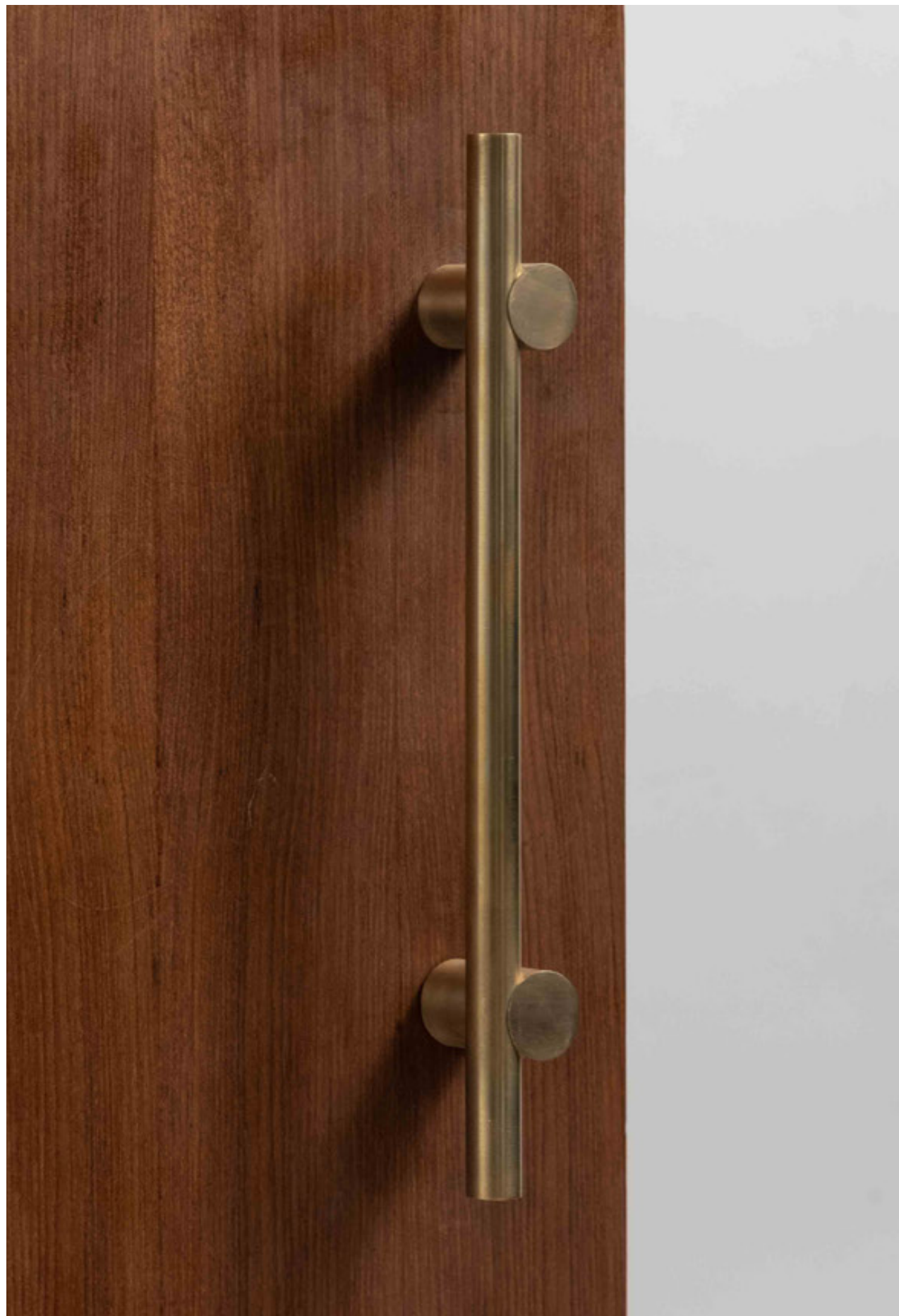

Offset Collection of Handles

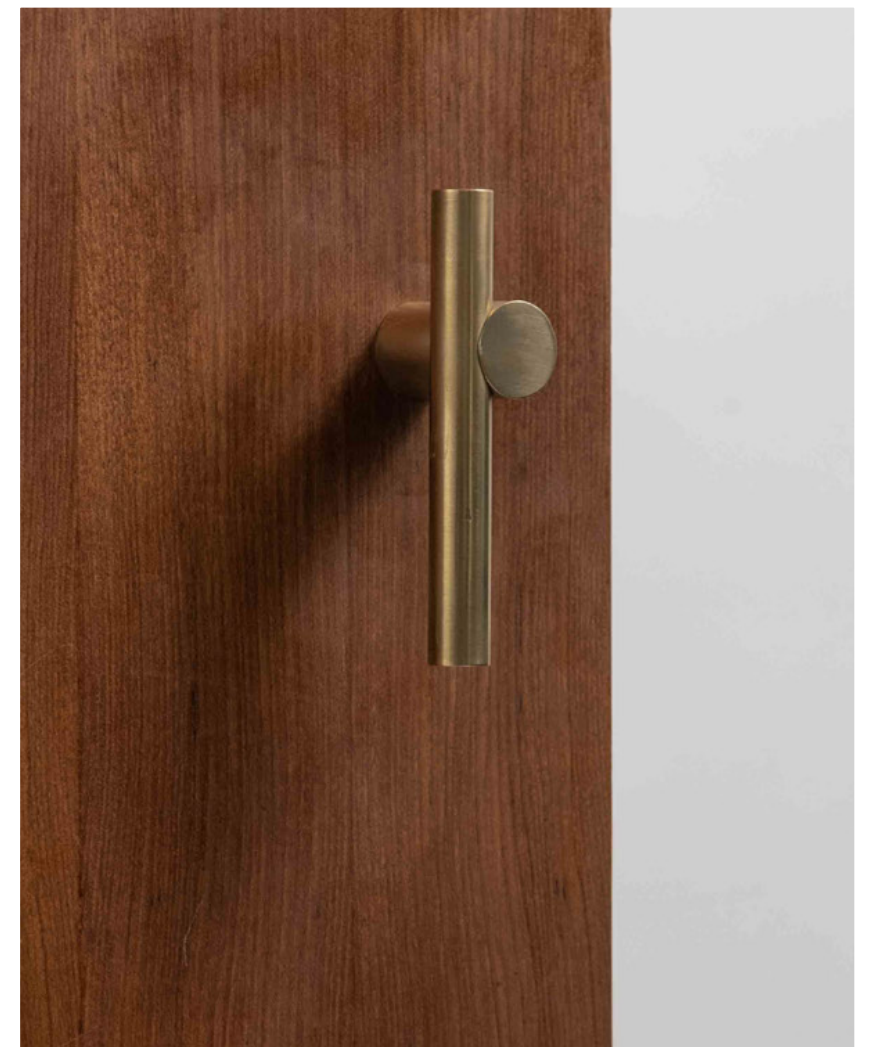

Specifications

**Material
& Finish**

Fabric

Finish

Brass ————— Matte / Aged / Blackened

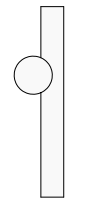
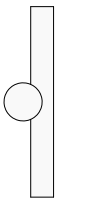
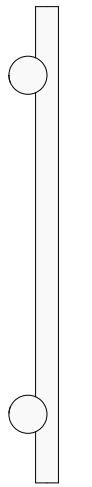
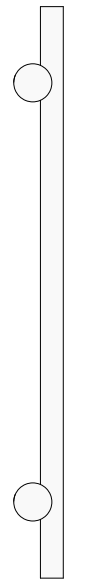
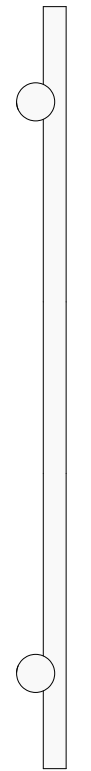
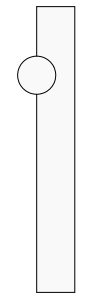
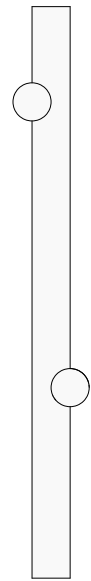
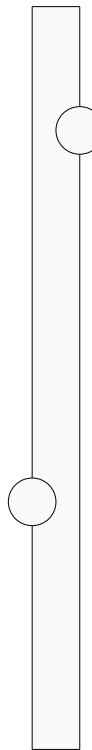
| Type 1 | Type 2 | Type 3 | Type 4 | Type 5 | Type 6 | Type 7 | Type 8 |
|--|---|--|--|--|---|--|--|
| Ø 12 mm H 96 mm | Ø 12 mm H 96 mm | Ø 12 mm H 240 mm | Ø 12 mm H 320 mm | Ø 12 mm H 400 mm | Ø 20 mm H 152 mm | Ø 20 mm H 320 mm | Ø 25 mm H 400 mm |
|  |  |  |  |  |  |  |  |



Cast & Faced Collection of Handles









Specifications

**Material
& Finish**

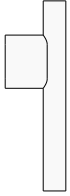
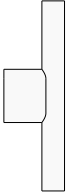
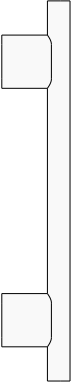
Fabric

Finish

| | | |
|-----------|-------|------|
| Brass | _____ | Cast |
| Aluminium | _____ | Cast |

| Type 1 | Type 2 | Type 3 | Type 4 | Type 5 | Type 6 | Type 7 | Type 8 |
|--|---|--|--|--|---|--|--|
| Ø 14 mm H 100 mm | Ø 14 mm H 100 mm | Ø 14 mm H 200 mm | Ø 14 mm H 300 mm | Ø 14 mm H 400 mm | Ø 20 mm H 150 mm | Ø 20 mm H 320 mm | Ø 20 mm H 420 mm |
|  |  |  |  |  |  |  |  |

Cast Bamboo Collection of Handles



Specifications

**Material
& Finish**

Fabric

Finish

Brass ————— Cast

| | | | | | | | | |
|---------------------|---------------------|---------------------|---------------------|---------------------|---------------------|---------------------|---------------------|---------------------|
| Type 1 | Type 2 | Type 3 | Type 4 | Type 5 | Type 6 | Type 7 | Type 8 | Type 8 |
| Ø 14 mm H 100 mm | Ø 14 mm H 100 mm | Ø 14 mm H 200 mm | Ø 14 mm H 300 mm | Ø 14 mm H 400 mm | Ø 20 mm H 150 mm | Ø 20 mm H 320 mm | Ø 20 mm H 420 mm | Ø 20 mm H 420 mm |

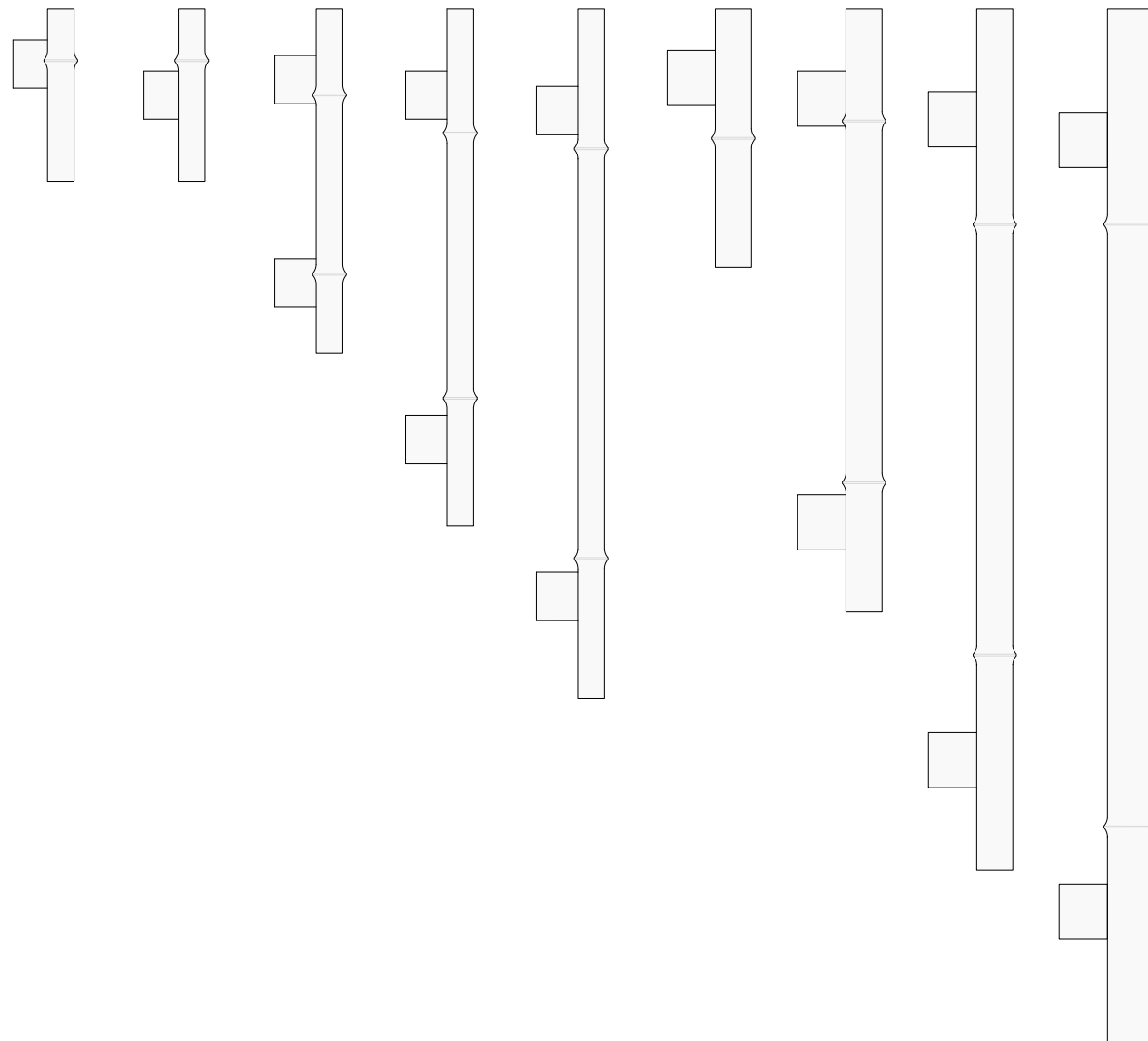

Bespoke

Gouge Edge Table

| | | |
|-------------------|-----------------|----------------------|
| Material & Finish | <i>Body</i> | <i>Finish</i> |
| | Reclaimed Burma | Oiled |
| Dimensions | <i>Table</i> | 3000 x 1050 x 740 mm |
| | <i>Bench</i> | 2800 x 400 x 400 mm |



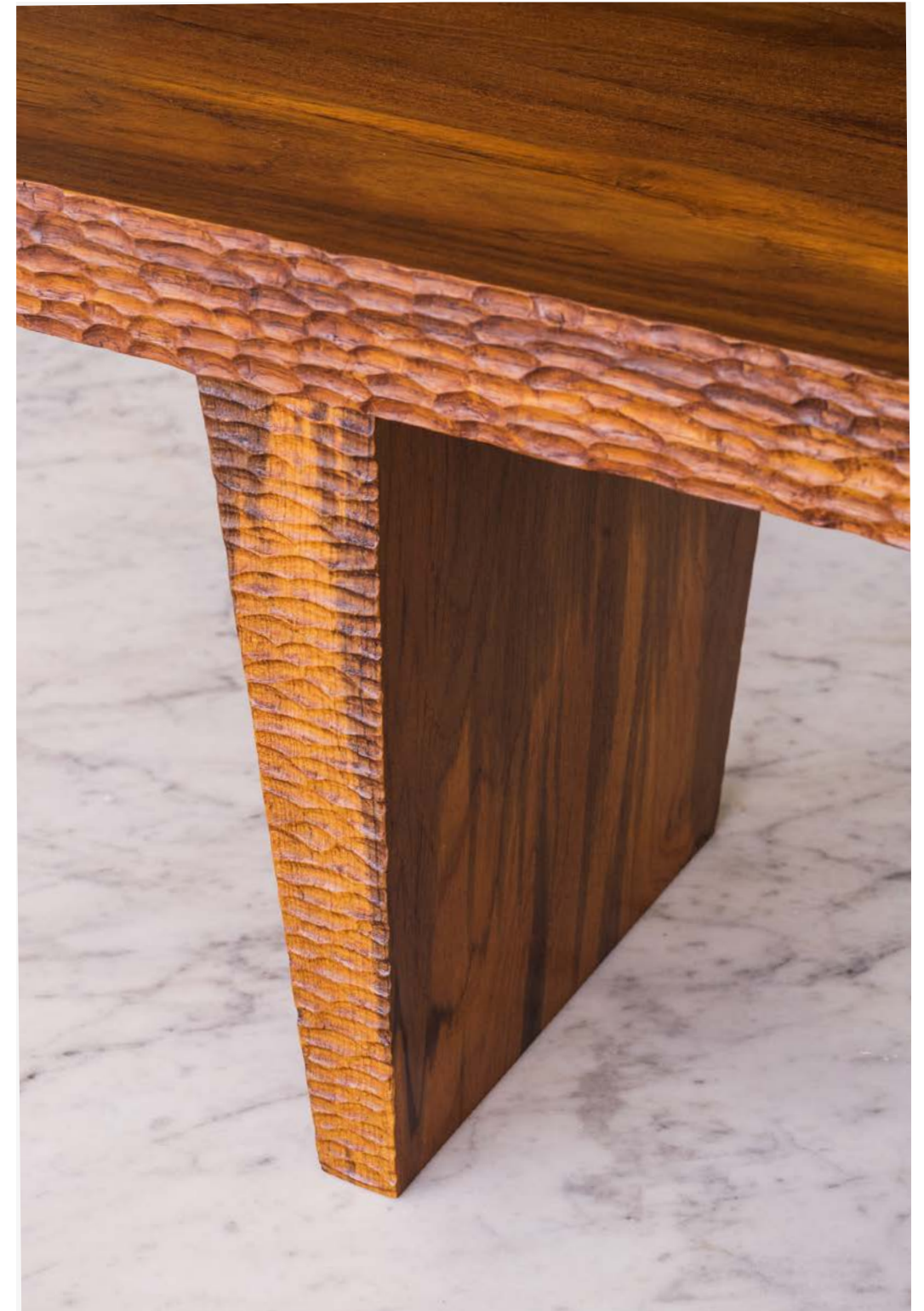

Flared Leg Table



| Material & Finish | Body | Finish |
|-------------------|----------------------|--------|
| | Reclaimed Burma | Oiled |
| Dimensions | 3000 x 1000 x 740 mm | |





Cast Brass Bench

| Material & Finish | Body | Finish |
|-------------------|-------|--------|
| | Brass | Cast |

Dimensions 1800 x 420 x 390 mm





Cast Brass Bench

| Material & Finish | Body | Finish |
|-------------------|----------------------|--------|
| | Brass | Cast |
| | Reclaimed Burma Teak | Oiled |
| Dimensions | Ø 1350 x 760 mm | |



Profiled Stone Console

| | | |
|-------------------|--------------------------|--------------------------|
| Material & Finish | <i>Body</i> Sandstone | <i>Finish</i> Leather |
| Dimensions | 1440 x 336 x 940 mm | |



Upholstered Bed

Material
& Finish

Body

Finish

Teak

Oiled

Upholstery by Safed

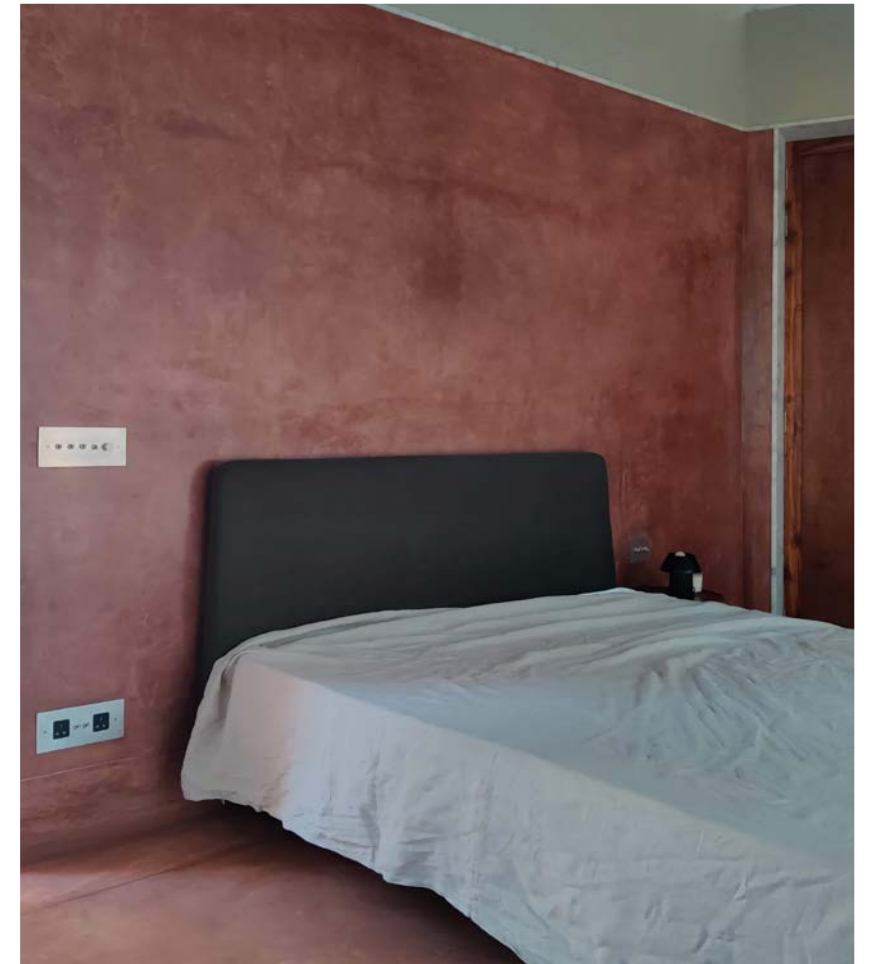

Wood Music Box



| Material & Finish | Body | Finish |
|-------------------|----------------------|--------|
| | Reclaimed Burma Teak | Oiled |
| Dimensions | 1350 x 1450 x 450 mm | |

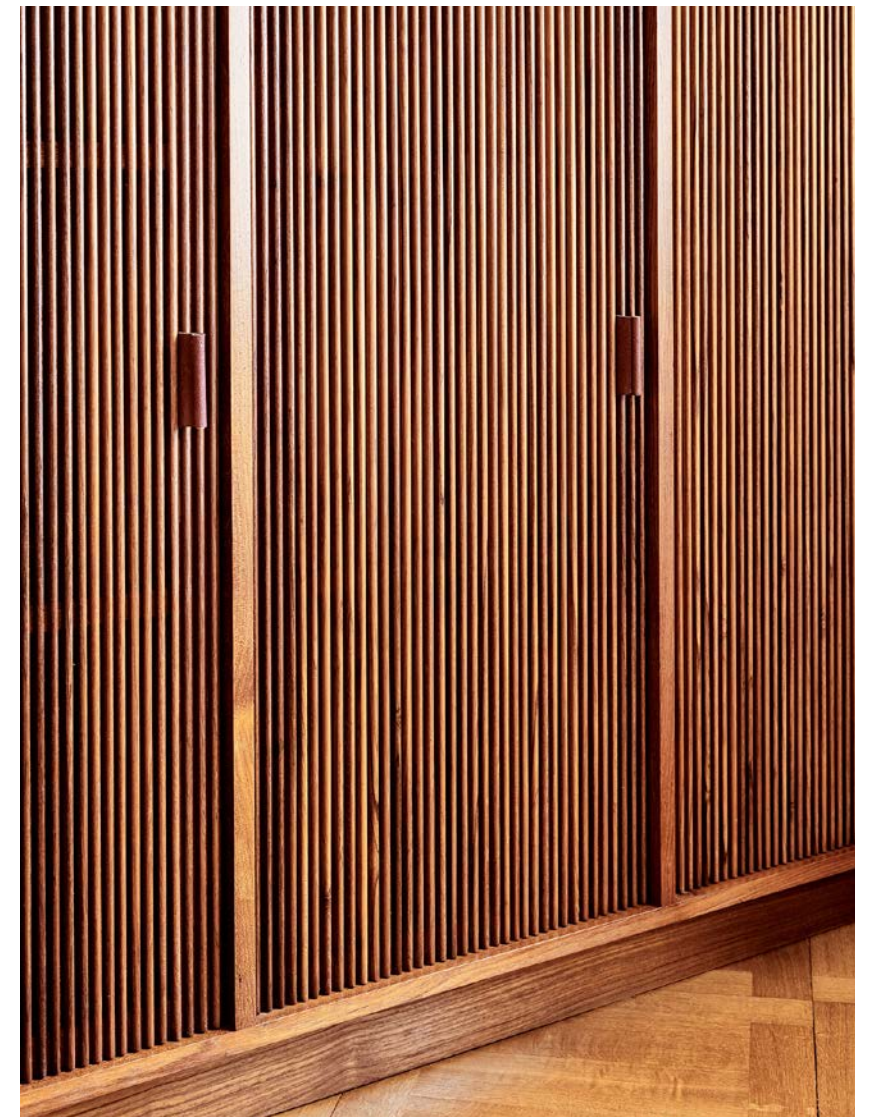

Wood Console



Material & Finish

Body

Finish

Teak

Oiled

Rosewood Knobs

Oiled

Dimensions

3100 x 1000 x 440 mm





Head Board

| Material & Finish | Body | Finish |
|-------------------|----------------|--------|
| | Teak | Oiled |
| | Rosewood Knobs | Oiled |

Dimensions 3100 x 1000 x 440 mm

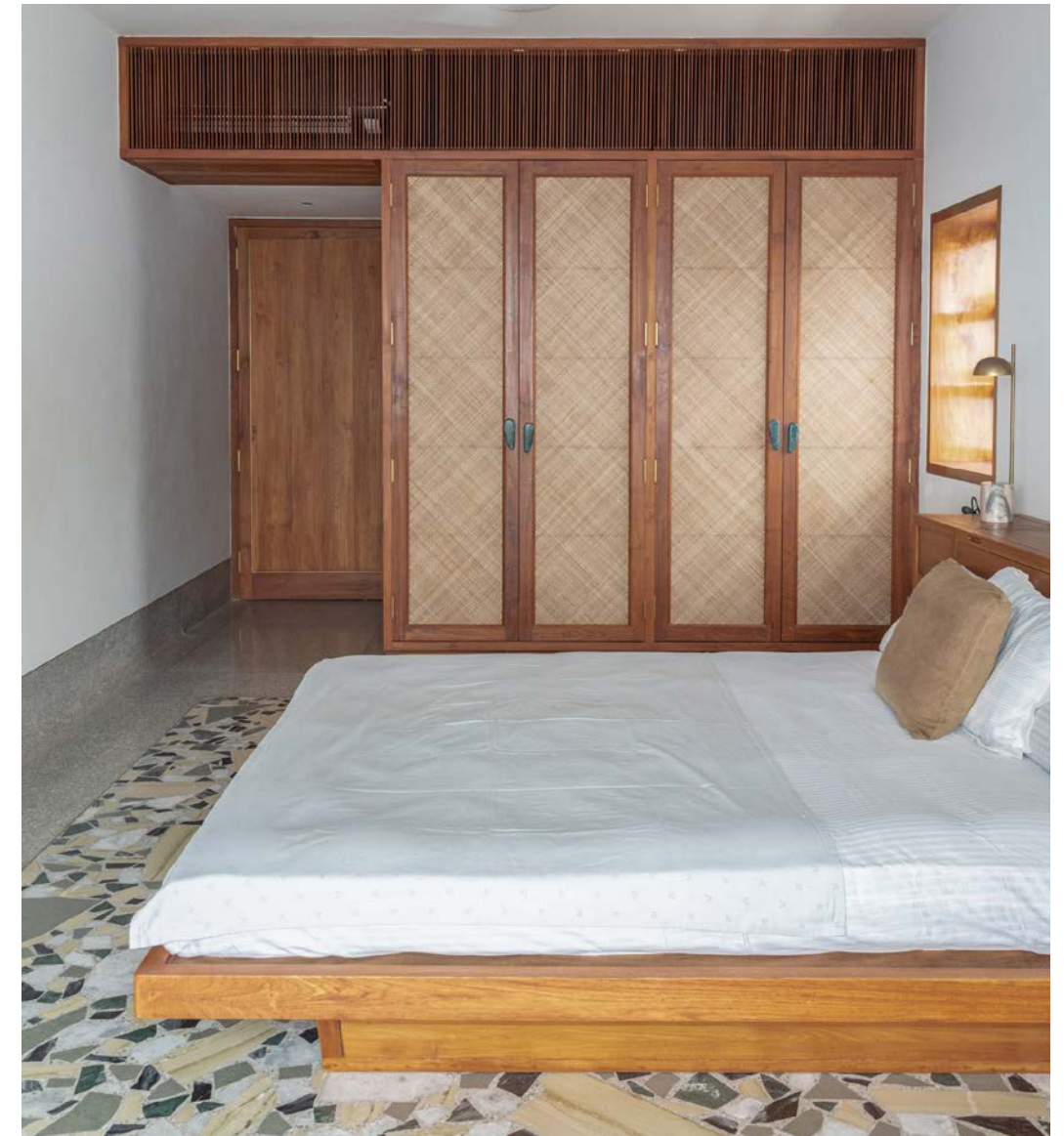



Two Level Desk

Material
& Finish

Body

Finish

Reclaimed Burma Teak

Oiled

Dimensions

1900 x 800 x 760 mm



Dome Uplight

Material
& Finish

Body

Finish

Brass

Polished

Dimensions

Dome

Ø 200 mm



Bespoke Front Facing Lights

Material
& Finish

Body

Finish

Brass ————— Blackened

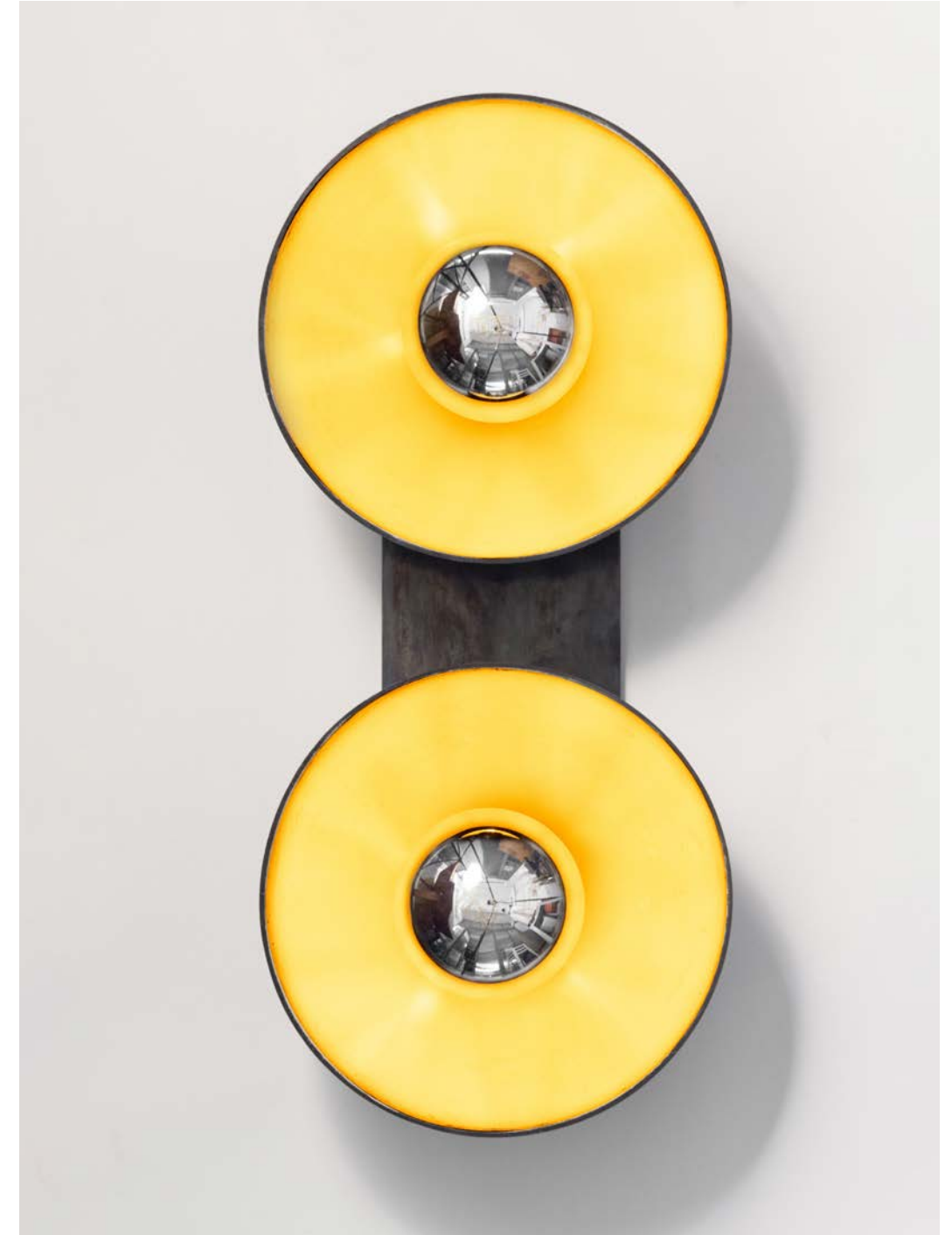

Materials



Burma Teak



New Teak



Mahogany



Oakwood



Rosewood



Black Stained Oak



Aluminium, Neutral Anodised



Aluminium, Black Anodised

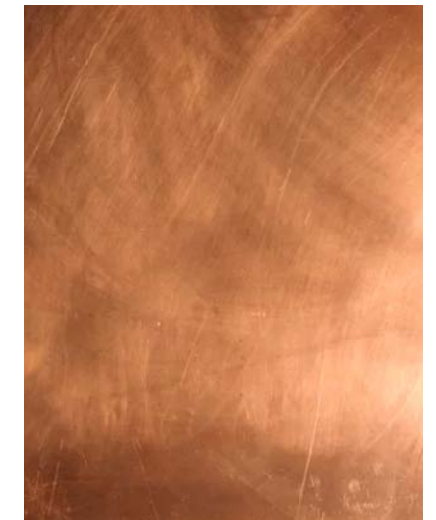

Copper



Brass, Polished



Brass, Blackened



Brass, Blackened



Stainless Steel



Mild Steel



Pink Marble

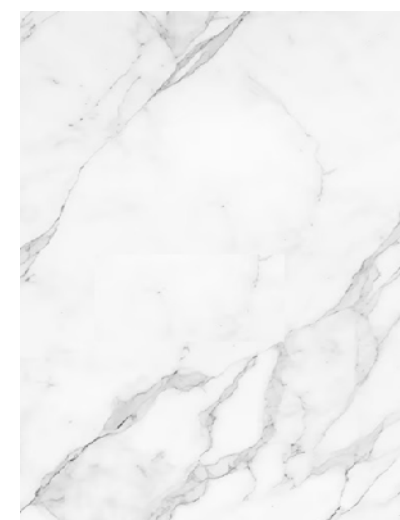

White Marble



Green Marble

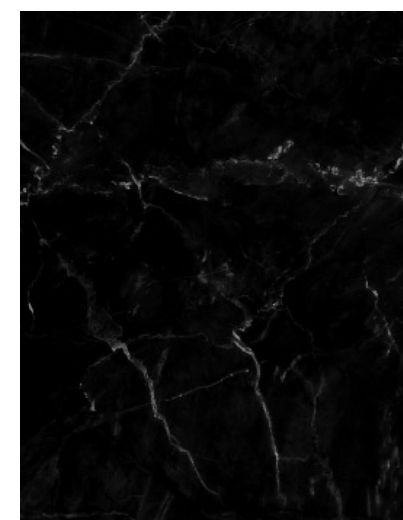

Black Marble



Terrazzo



Sandstone

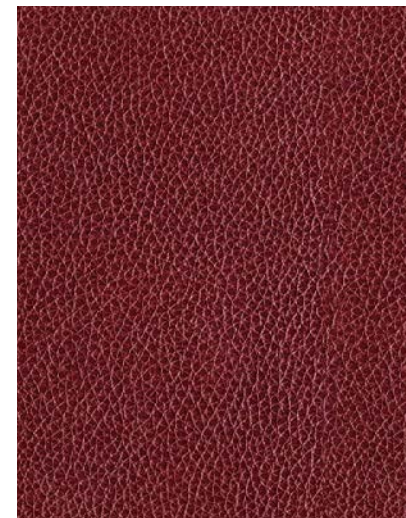

Red Leather



Green Leather

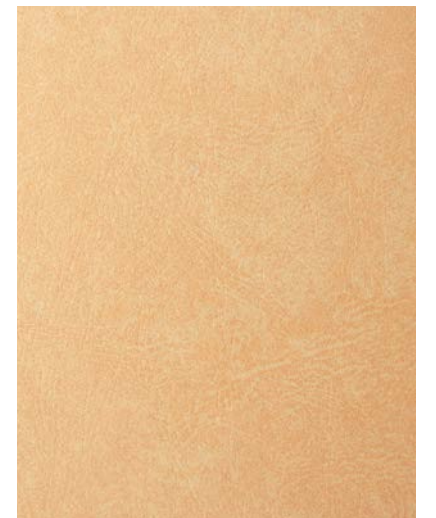

Natural Buffalo Leather



Recycled Rope



Dyed Jute

*Stockists*¹

| | |
|--------------------|------------------------|
| By Mölle | Hattem, Netherlands |
| Deeya Paris | Paris, France |
| Graanmarkt 13 | Antwerp, Belgium |
| Kollekted By | Oslo, Norway |
| Le Mill | Mumbai, India |
| Mikado | Reykjavík, Iceland |
| Mundano | Porto, Portugal |
| Pantoufle | Rotterdam, Netherlands |
| Ryoko senses salon | Berlin, Germany |
| The Front Room | Melbourne, Australia |
| Tula | Kolkata, India |

¹

The above information is accurate as of Jan 2024.

Credits

Photography

Ariel Huber
Samuel Barclay
Paul Michelin
Kenneth Rodrigues
Shriram Rajakumar

Product Design

Samuel Barclay
Saleem Bhatri
Paul Michelin
Kenneth Rodrigues
Dhwani Mehta
Tanay Kandpal
Jumana Motiwala
Abhishek Das
Gaurav Edwanker
Raunaq Sandhu
Isha Shah
Abishai Choragudi
Aryaa Bhagawat

Editorial

Raseel Sehmi
Erica Barclay

Catalogue Design

Shriram Rajakumar

*Team*¹

| | |
|----------------------|--|
| Co-Founders | Saleem Bhatri Samuel Barclay Erica Barclay |
| CEO | Raseel Sehmi |
| Creative Direction | Kenneth Rodrigues |
| Product Design | Raunaq Sandhu Isha Shah |
| Communication Design | Shriram Rajakumar |
| Sales Coordination | Sarika Ranadive |
| Accounts | Priyanka Tawde |
| Production | Prashant Gurav |
| Workshop Management | Mallika Amin |
| Workshop Technicians | Devilal Suthar Sharwan Suthar Tikuram Suthar Abdul Rahim Shaikh Munavvar Hasmi Nilesh Jadhav Hamid Mulani Savappa Gaddevoor |

1

The above information is accurate as of Jan 2024.

Studio

A-49, Nandiyot Industrial Estate
Andheri Kurla Road
Mumbai – 400072, India

Contact

mail@casegoods.in
+91 8097270837
www.casegoods.in
@casegoods.in

